

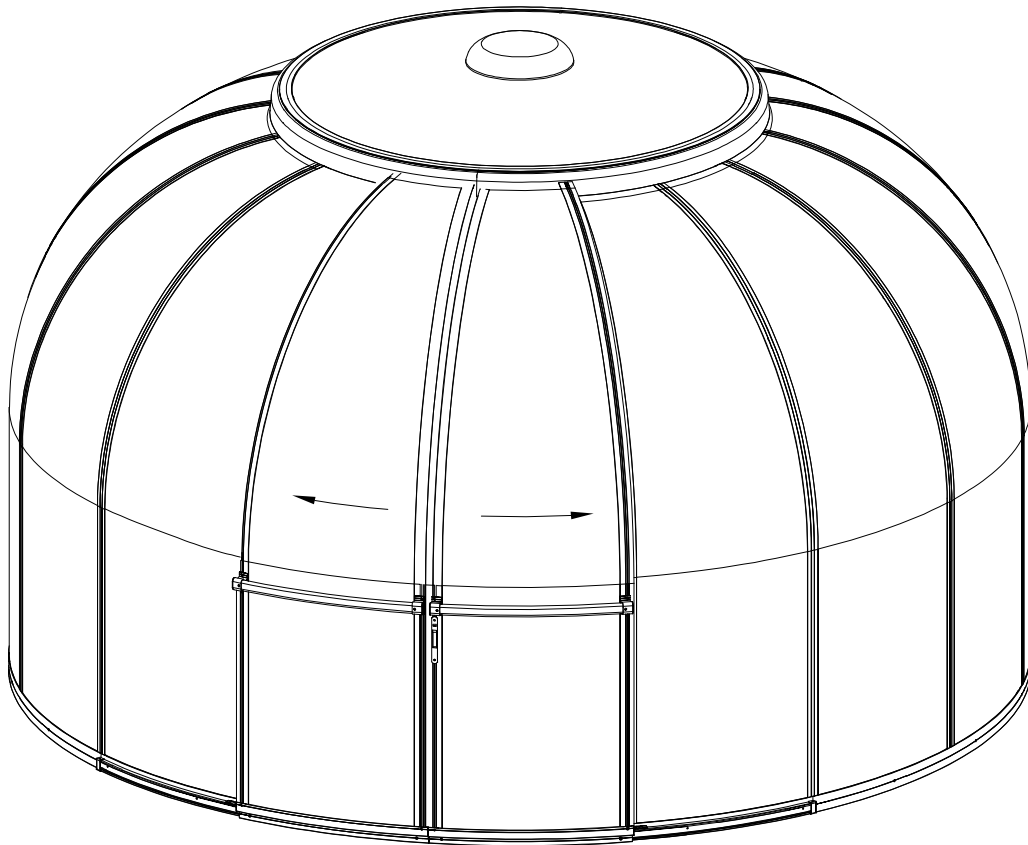

Montagevejledning



**MODEL: SCANDIC SKYDOME RUND 16,6
DIAMETER 460CM. TOTALHØJDE 291CM. DØR 165CM
LÆS VENLIGST HELE VEJLEDNINGEN FØR MONTERING**

INDHOLD

1. Gode råd om monteringen	Side 1
2. Liste over dele.....	Side 2
3. Dør samling.....	Side 3- 12
4. Top dæksel samling.....	Side 13-15
5. Bundramme samling.....	Side 16-17
6. Montage af stellet	Side 18- 32
7. Montage af gardiner.....	Side 33- 34

Gode råd om montering og vedligeholdelse

1. Af sikkerhedsmæssige årsager anbefaler vi kraftigt, at dette produkt samles af mindst to personer.
2. Nogle komponenter har skarpe metalkanter. Vær forsigtig, når du håndterer metalkomponenter. Bær handsker, sko og beskyttelsesbriller under montering.
3. Læg alle komponenterne på et blødt tæppe eller tæppe for at undgå ridser eller skader.
4. Du må IKKE klatre eller stå på taget. Tunge genstande bør ikke lænes mod drivhuset.
5. Hold taget fri for sne, snavs og blade. Større snemængder bør fjernes.
6. Evt. ridser i malingen vil ikke beskadige aluminiumpanelerne.
7. Rengøring: bruge et mildt rengøringsmiddel og skyl efter med rigeligt vand. Brug ikke acetone, slibende eller stærke rengøringsmidler. Til rengøring af akrylplader og PLEXIGLAS anbefales lunkent sæbevand eller stærkt fortyndede opløsninger af milde, syntetiske rengøringsmidler. Til arbejdet anbefales en blød klud eller svamp. For at fjerne sæberester eftervaskes med rent vand. **PAS PÅ IKKE AT RIDSE PLEXIGLASSET!**

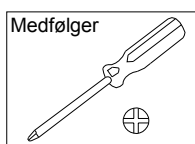

Du får også brug for dette:

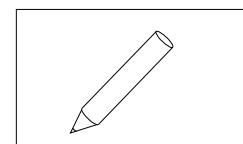
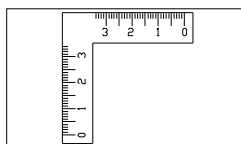
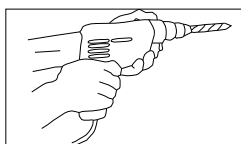
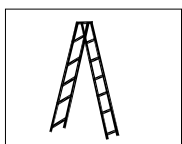
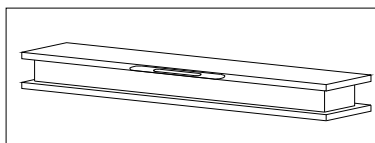
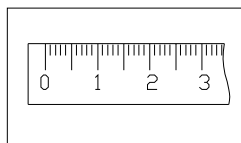
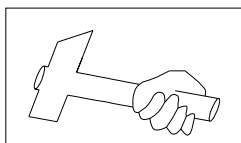
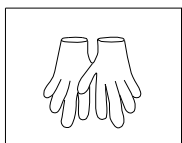





















Vi anbefaler at produktet samles af mindst to personer





























Vigtigt! PAS PÅ IKKE AT RIDSE PLEXIGLASSET!

SCANDIC SKYDOME RUND 7,6

DEL	NR	STK
	L01A	8
	L01B	7
	L02A	3
	L02B	1
	L05A	1
	L06A	2
	L07A	2
	L08A	1
	L09A	1
	L09B	1
	L10A	1
	L11A	7
	L11B	2
	L12A	4

DEL	NR	STK
	Y1	14
	Y2	2
 3.23m	J149	28
 3.31m	J149	4
 14m	J149	1
 3.25m	J152	2
 1.8m	J108	1

DEL	NR	STK
	D318	6
	D319	2
	D320	4
	D321	8
	D278	2
	D279	2
	D332	2

DEL	NR	STK
	J157	4
	J159	2
	J212	6
	S60A M6X16	12
	S62A M6X25	12
	Z08A ST4.2X16	14
	M01A M6	10
	M07A M6	8
	S15A M4X10	2
	H22 M4	2
	H21	1
	J161	6
	D284	5
	A76	8
	H132	2
	K2	1
	H31-1	1
	S61A M6X30	4
	J156	16
	Z13A ST5X40	16

Medfølger:

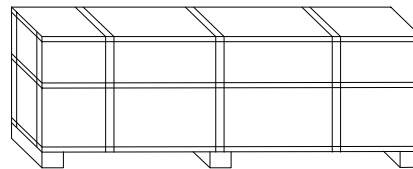
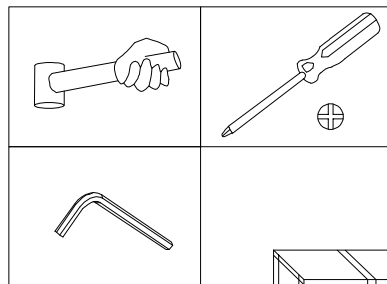



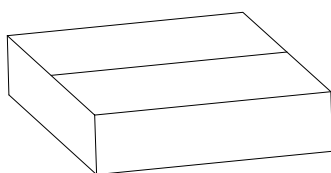

Glas Nr. 1

DEL	NR	STK
	K1	1





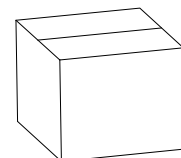

ALU. Box Nr. 1

DEL	NR	STK
	A86	7
	J163	58
	A87	1
	J164	74
	H130	135



Gardin Box Nr. 2

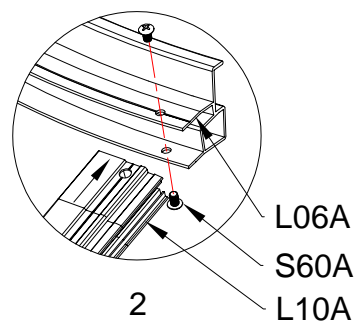
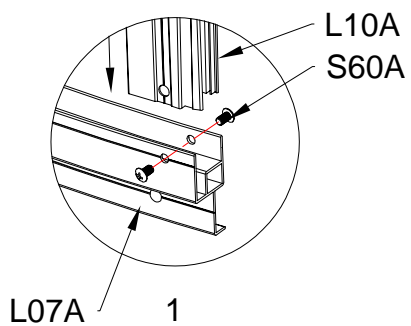
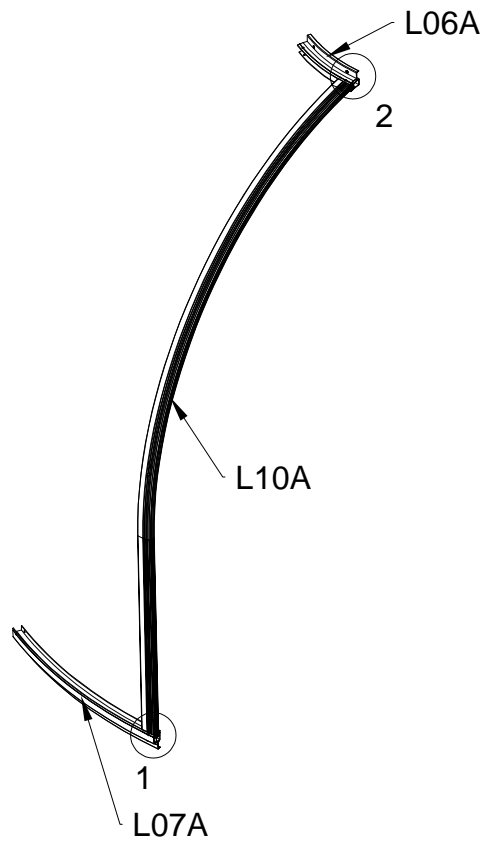

DEL	NR	STK
	L06A	1
	L07A	1
	L10A	1
	S60A M6X16	4

Venstre dør

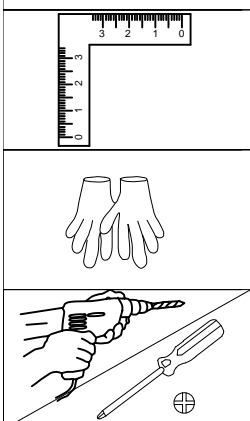

Monter L06A & L07A til hver ende af L10A, brug S60A.



DEL	NR	STK
	Y2	1
 3.31m	J149	2
 0.83m	J149	1

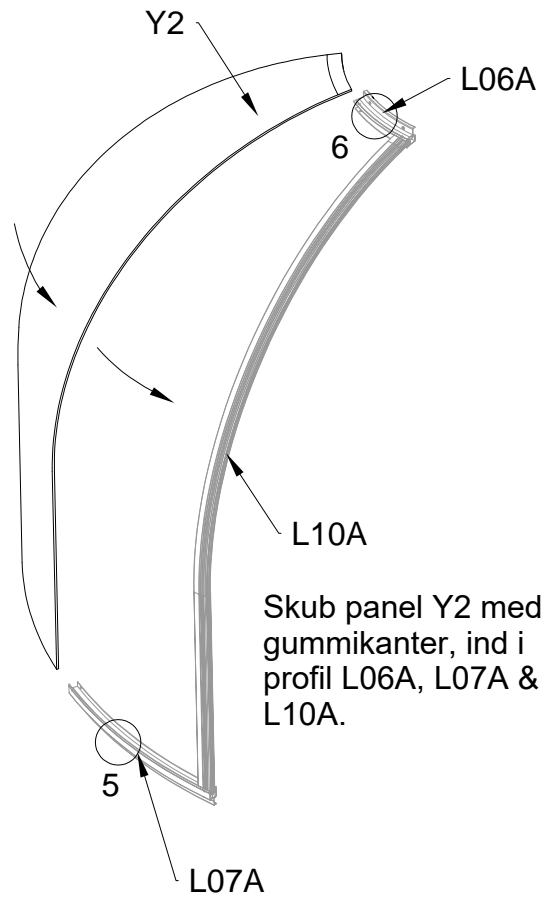
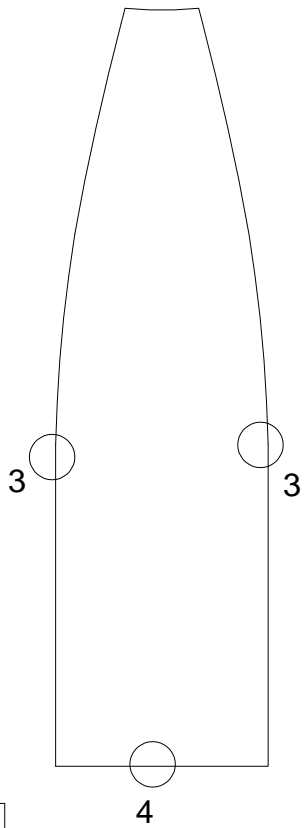
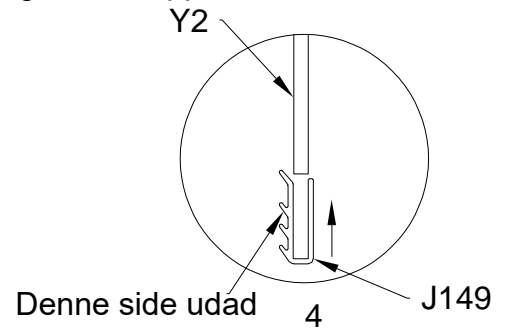
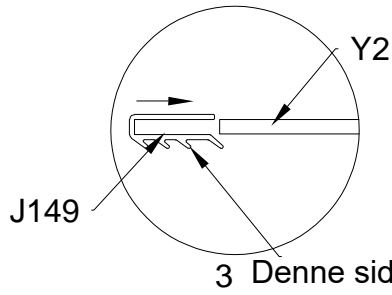

Venstre dør

Monter gummi J149 rundt på siderne og bunden af Y2 panelet som vist her. Bemærk at der ikke skal monteres gummi i toppen.

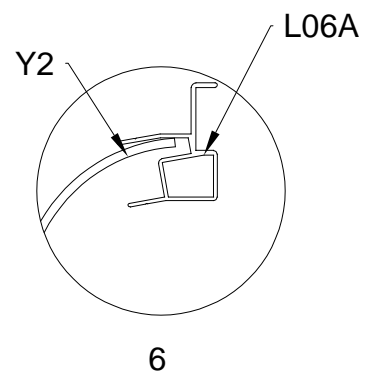
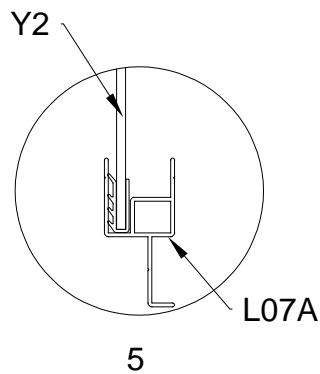
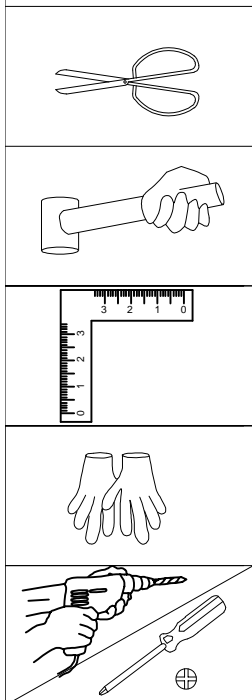

Skub panel Y2 med gummikanter, ind i profil L06A, L07A & L10A.



DEL	NR	STK
	L09B	1
	J152	1
	S60A M6X16	4

Venstre dør



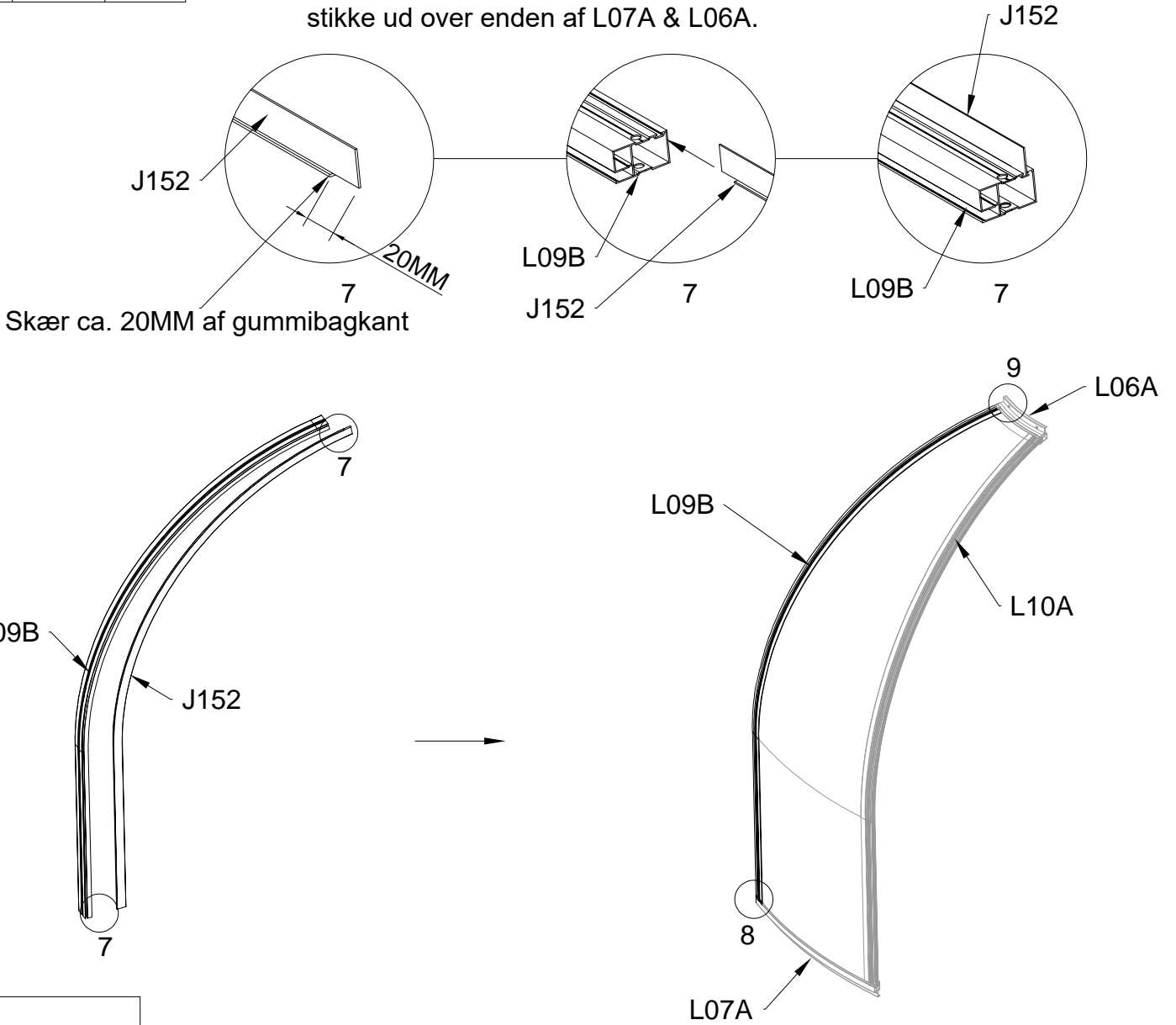



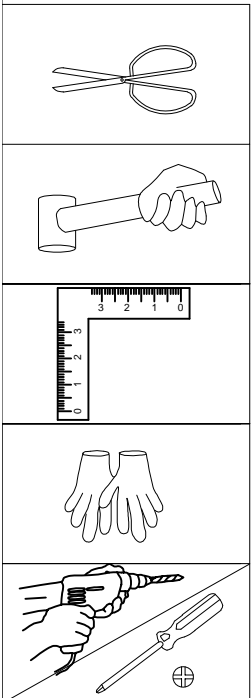
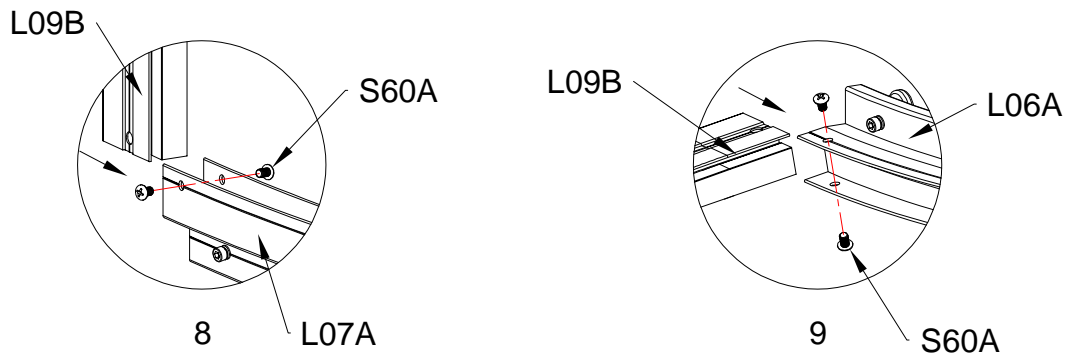

Skub gummi J152 ind i L09B. Skær ca. 20mm af bagkanten på gummi, så forreste gummilæbe, kan stikke ud over enden af L07A & L06A.



Saml L09B med L06A & L07A, brug S60A.



Venstre dør

DEL	NR	STK
	A76	4
	D320	2
	L11B	1
	J212	2
	S60A M6X16	6
	S62A M6X25	4
	J157	2
	J108	1

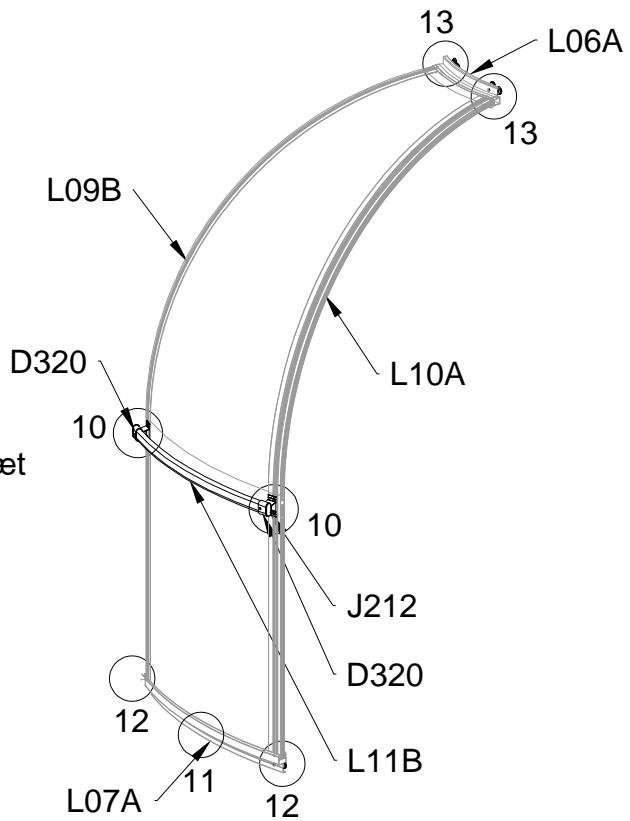

Monter L11B & 2 x D320 beslag, brug S60A. Sæt dæksel J212 i hver ende af L11B.

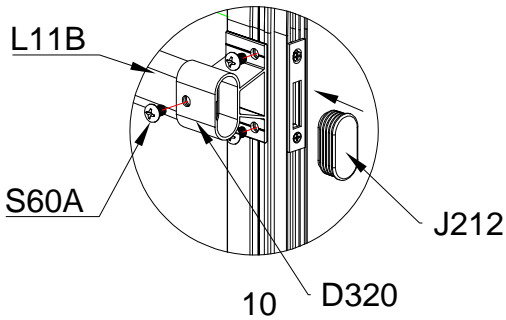

2 x Hjul sæt i bunden monteres løst, derefter dæksel J157

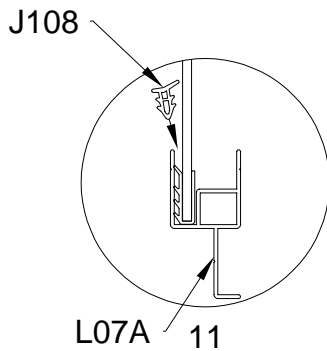

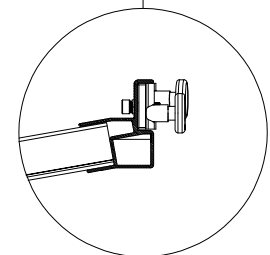
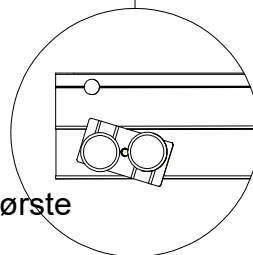
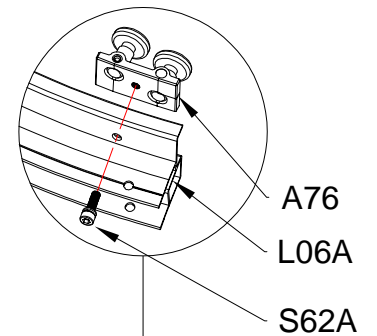
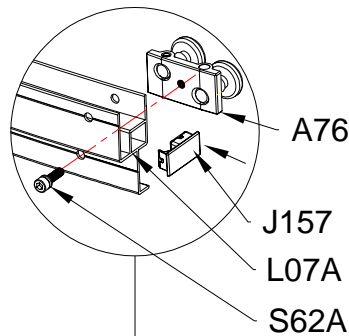

Monter gummi J108 udvendigt på L07A.

2 x Hjul sæt i toppen monteres og færdigspændes



Bemærk: Skru S62A skal i første omgang, kun lige tage fat i hjulsættet i bunden. A76 skal kunne dreje ret frit for senere montage og først derefter spændes S62A skruen. (Figur 12)



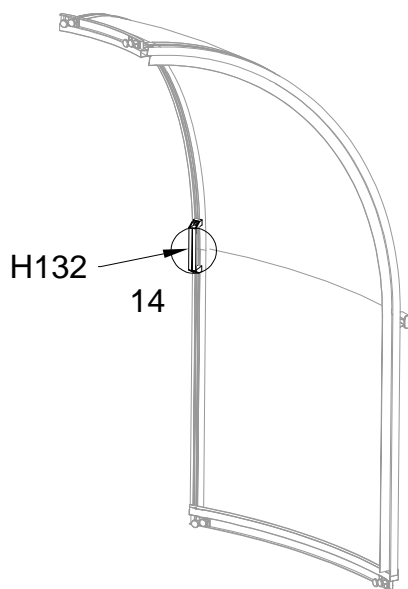

DEL	NR	STK
	H132	1
	S62A M6X25	2

Venstre dør

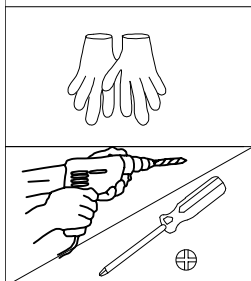
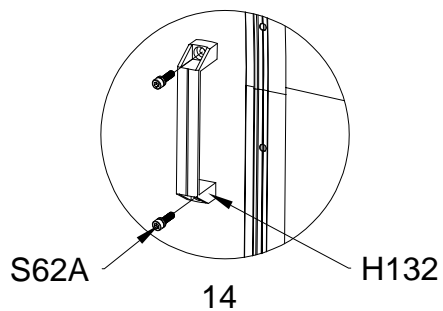

Det indvendige dørhåndtag H132 fastgøres med skrue S62A.





DEL	NR	STK
	L06A	1
	L07A	1
	L09A	1
	J152	1
	S60A M6X16	4

Højre dør

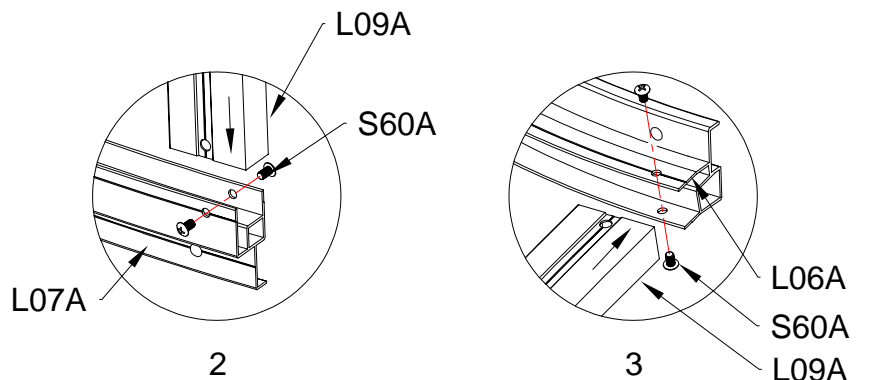
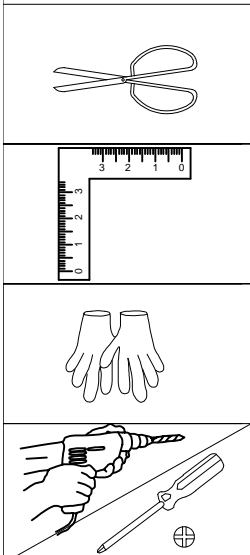
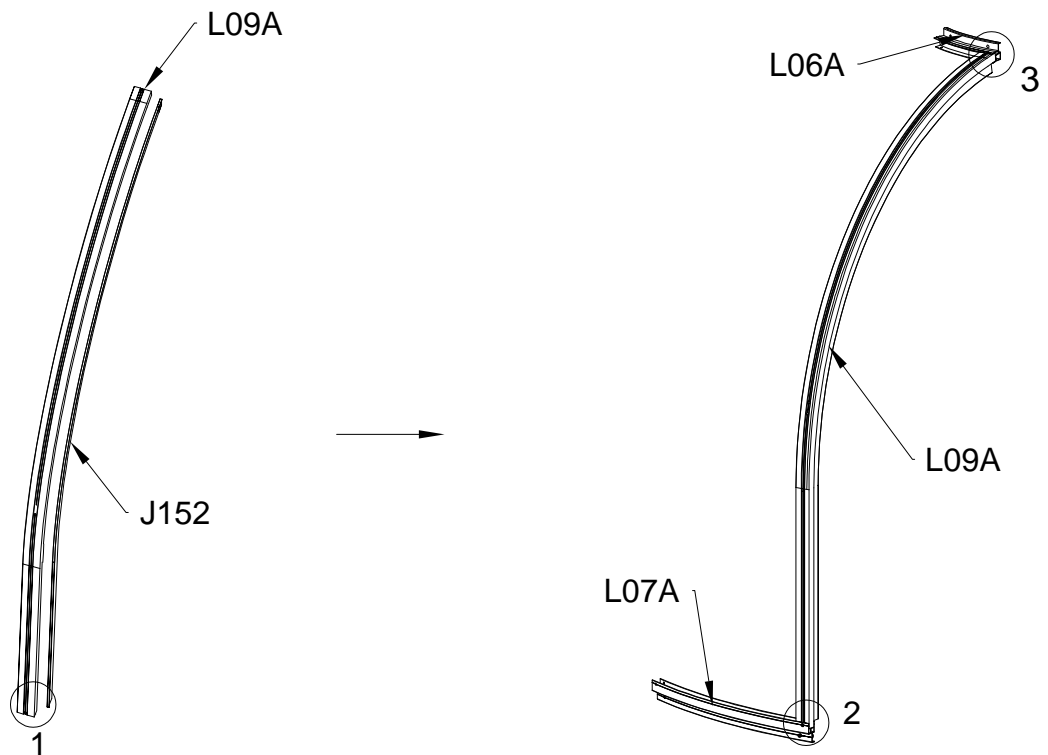
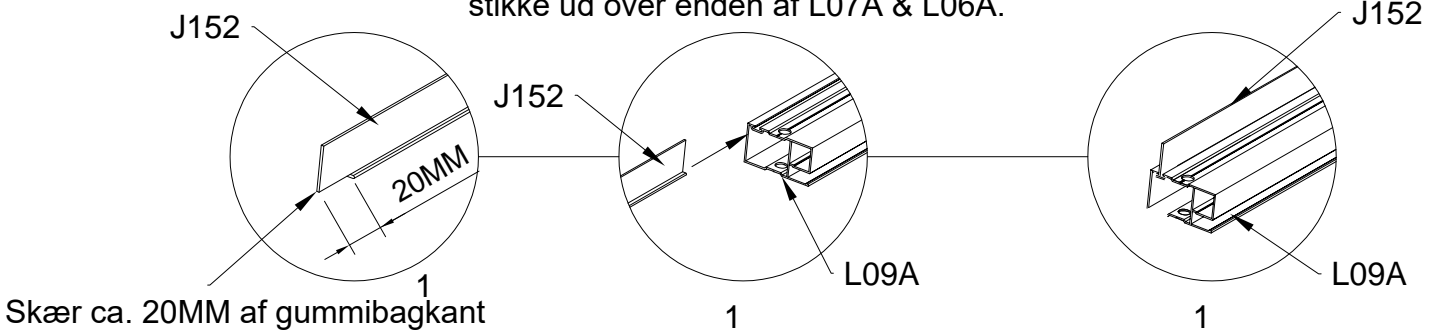
Skub gummi J152 ind i L09A. Skær ca. 20mm af bagkanten på gummi, så forreste gummilæbe, kan stikke ud over enden af L07A & L06A.



Monter L06A & L07A foroven og forneden på L09A med skrue S60A.

DEL	NR	STK
	Y2	1
 3,31m	J149	2
 0,83m	J149	1



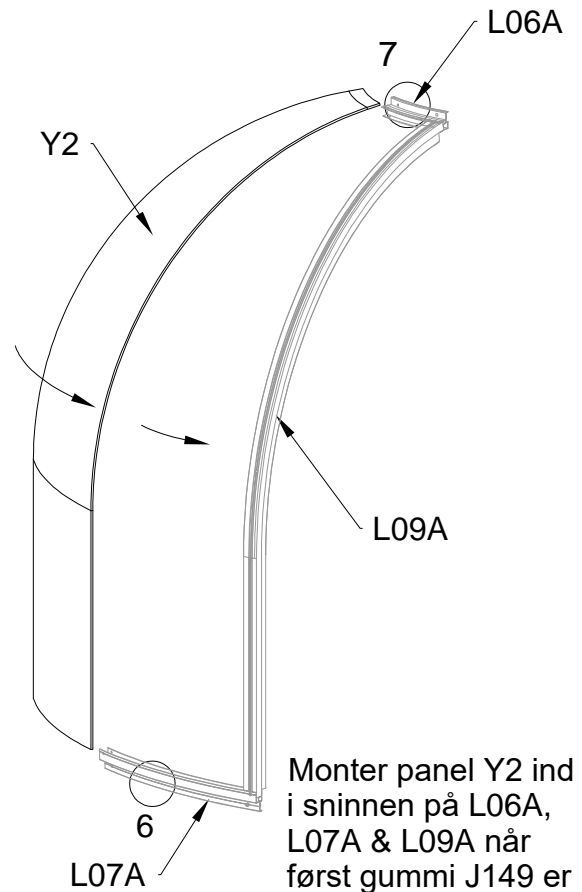
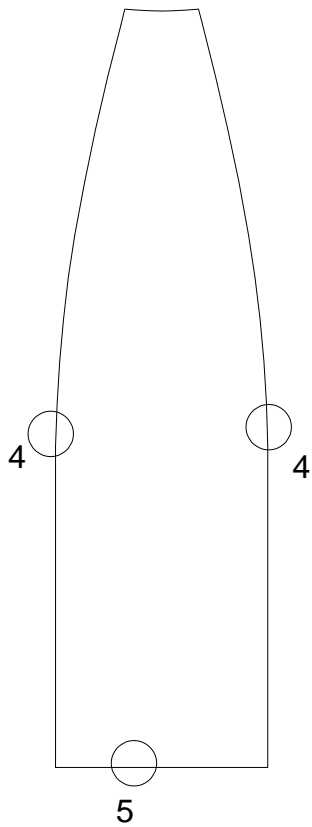
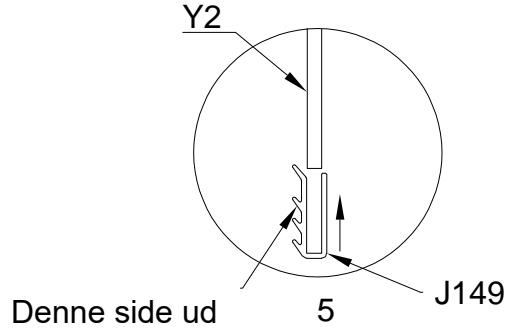
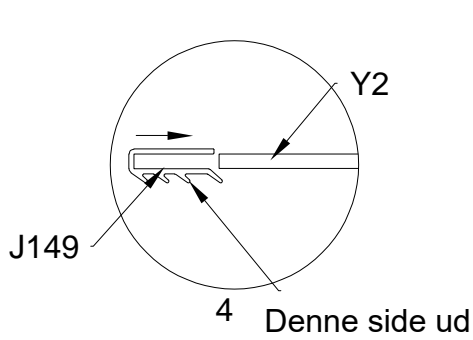

Højre dør

Monter gummi J149 rundt på siderne og bunden af Y2 panelet som vist her. Bemærk at der ikke skal monteres gummi i toppen.

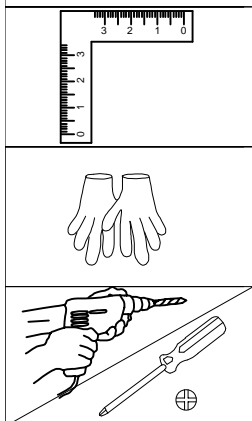
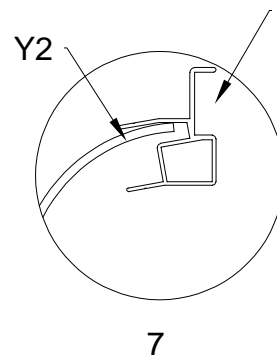
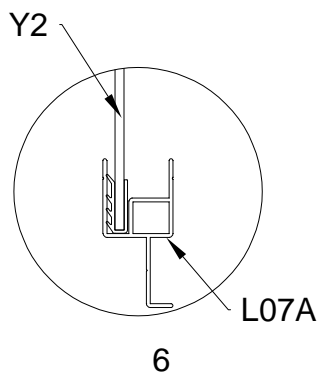

Monter panel Y2 ind i sninnen på L06A, L07A & L09A når først gummi J149 er monteret på panelet Y2



DEL	NR	STK
	L08A	1
	D320	2
	L11B	1
	J212	2
	S60A M6X16	10

Højre dør

L08A monteres med L06A & L07A, brug S60A.

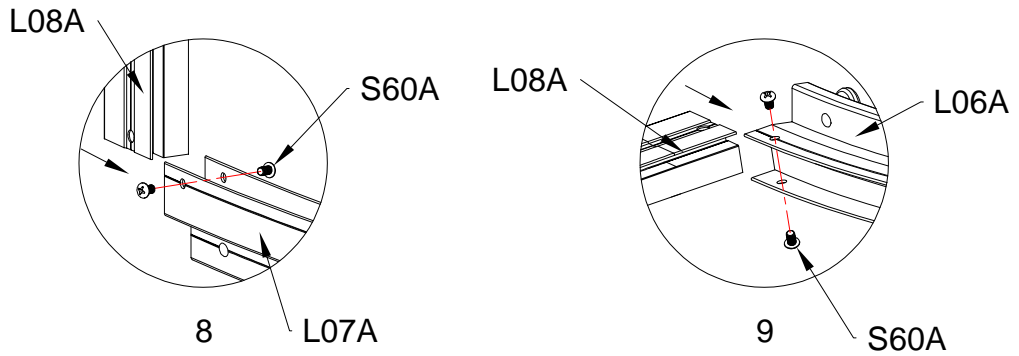



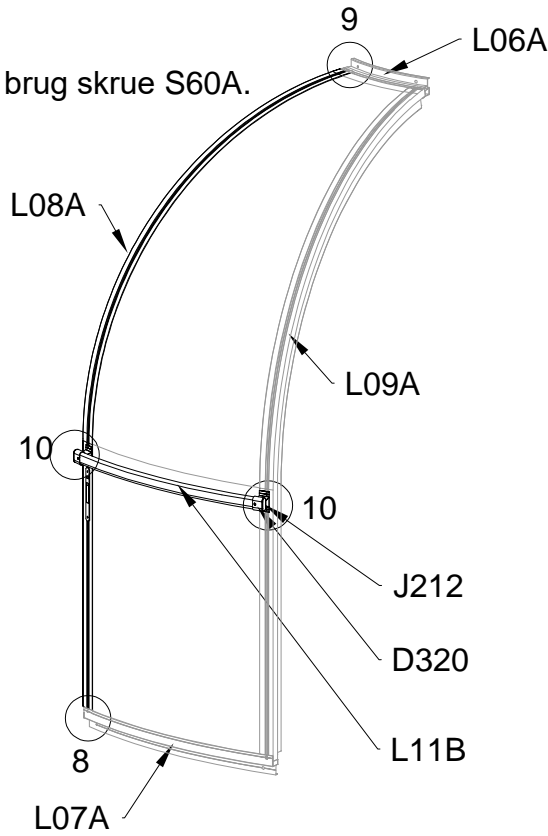

Monter L11B & 2 x D320 beslag, brug skrue S60A.

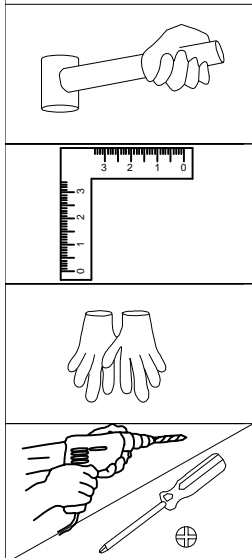
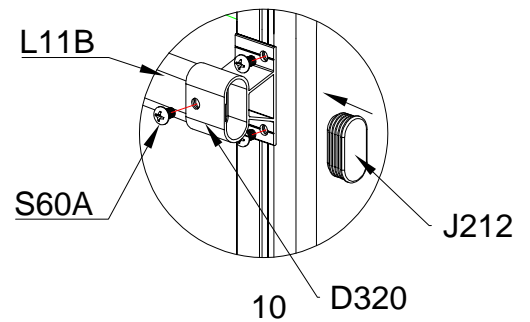

Sæt dæksel J212 i hver ende af L11B.



DEL	NR	STK
	A76	4
	S62A M6X25	4
	J157	2
 0.75m	J108	1

Højre dør

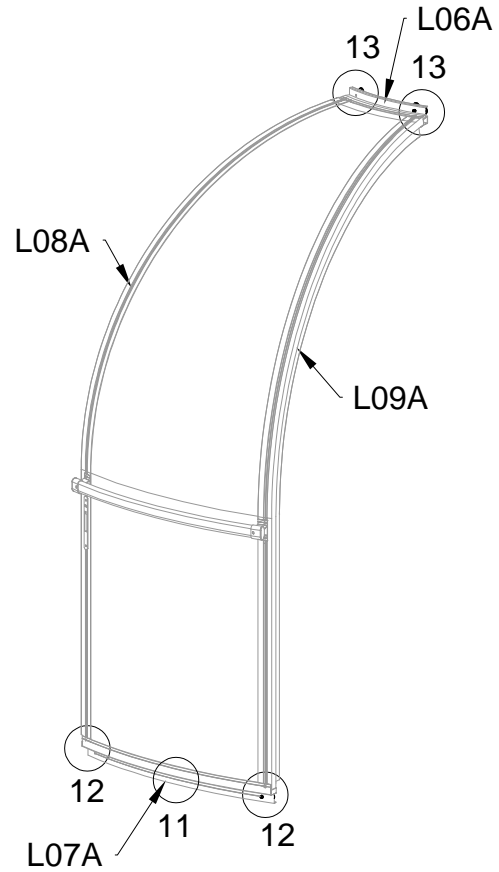

Monter gummi J108 udvendigt på L07A.

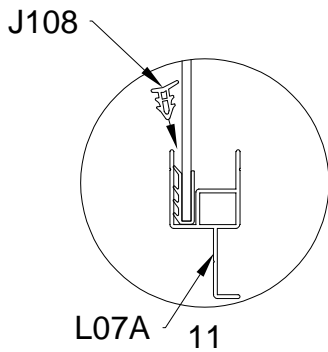

2 x Hjulsæt i bunden monteres løst, derefter dæksel J157

2 x Hjulsæt i toppen monteres og færdigspændes.

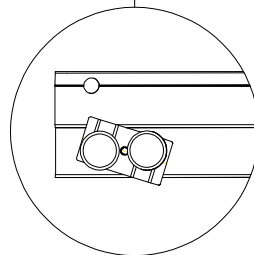
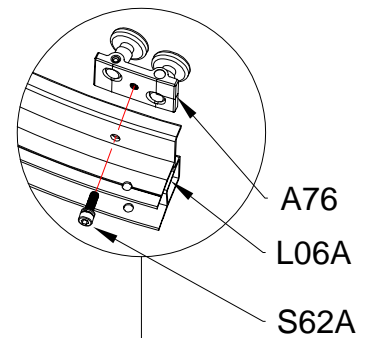
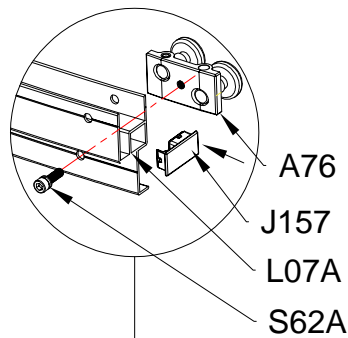

12

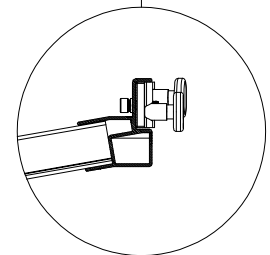



13

Bemærk: Skruer S62A skal i første omgang, kun lige tage fat i hjulsættet i bunden. A76 skal kunne dreje ret frit for senere montage og først derefter spændes S62A skruen. (Figur 12)

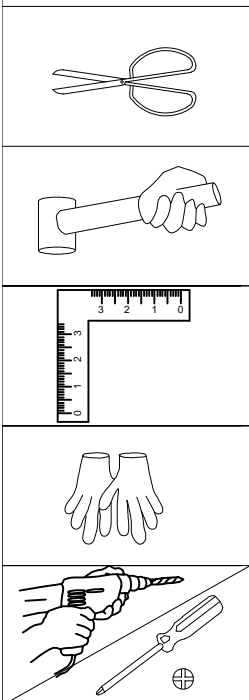
Fastgør hjulsæt A76 på L06A med skruer S62A.



DEL	NR	STK
	H132	1
	S62A M6X25	2

Højre dør

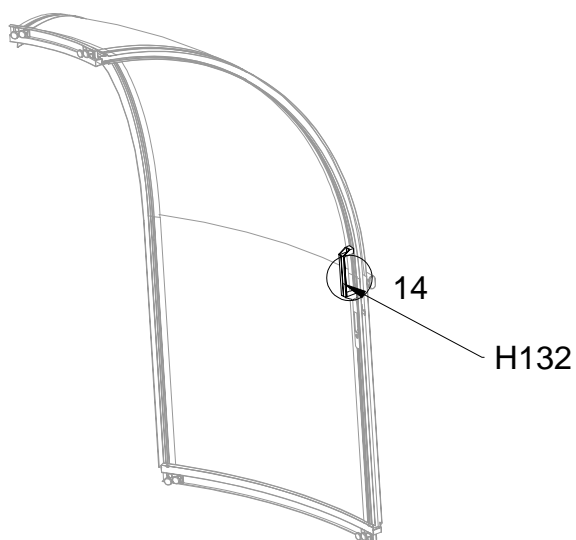

Det indvendige dørhåndtag H132 fastgøres med skrue S62A.

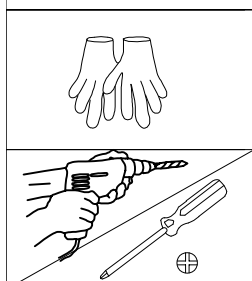
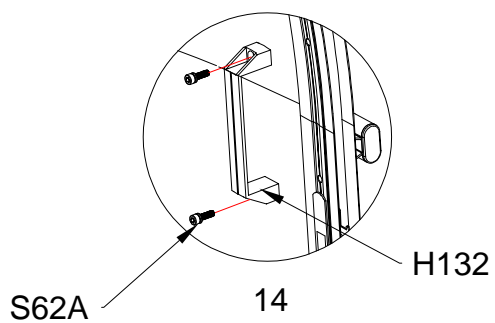

Top Dæksel samling

DEL	NR	STK
	K1	1
	K2	1
	S61A M6X30	4

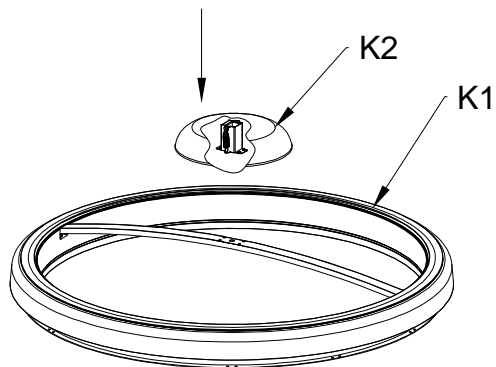
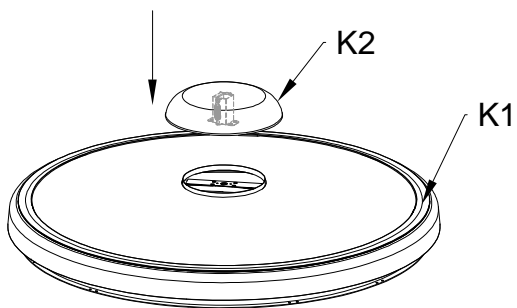

Den mindre K2 top skal monteres på K1 med S61A skruer

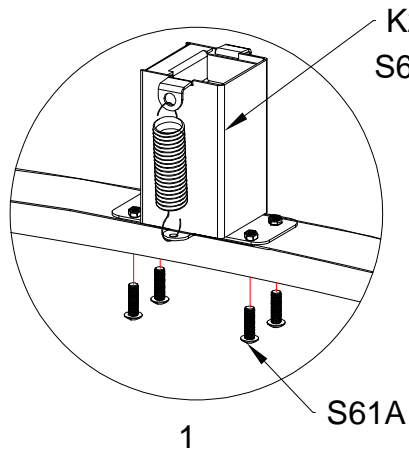
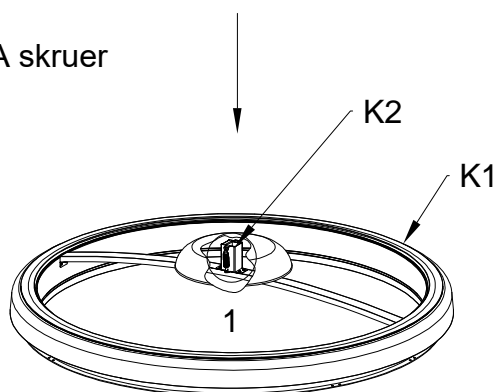

S61A Skruer må ikke overspændes.

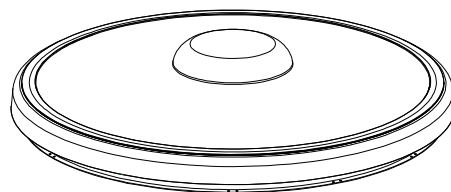

Efter montagen.

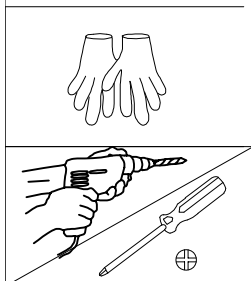

DEL	NR	STK
	H31-1	1

Auto-open montage

Monter cylinder H31-1 som vist her

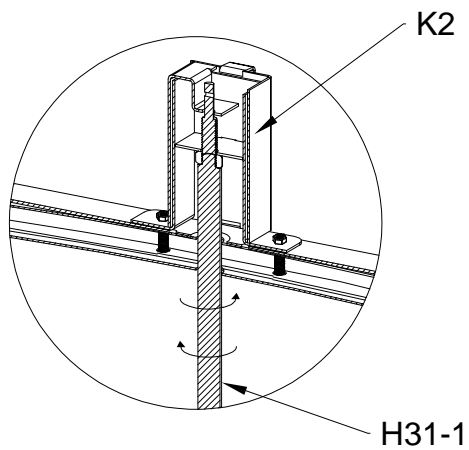
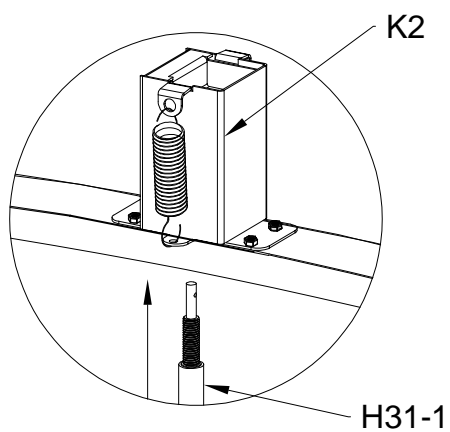
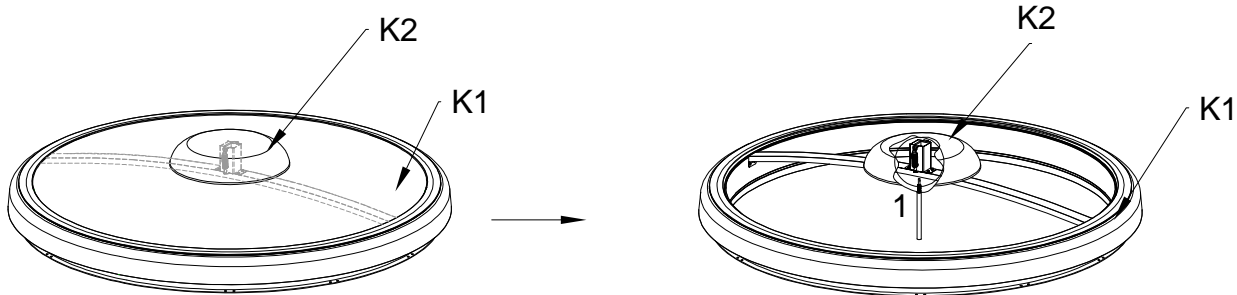

Gevindet på cylinder H31-1 kan justeres mere eller mindre i for at ændre, hvor meget K2 toppen skal åbne op for at cirkulere luften ind og ud af huset.



DEL	NR	STK
	H130	132

Gardin hjul montage

Bemærk, skal jo kun monteres, hvis du har tilkøbt gardinsæt

Afmonter plastdæksler fra K1 ringen

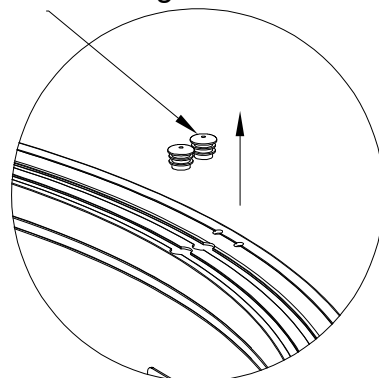
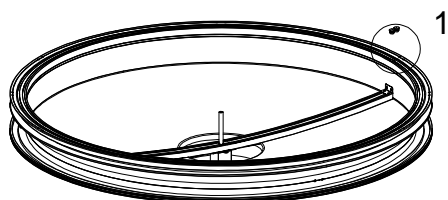

1

Skub alle gardin hjul H130 ind i skinnerne. 74 x H130 i den indre ring (37 stk til højre og 37 stk til venstre) samt 58 x H130 i den ydre ring (29 stk til højre og 29 stk til venstre)

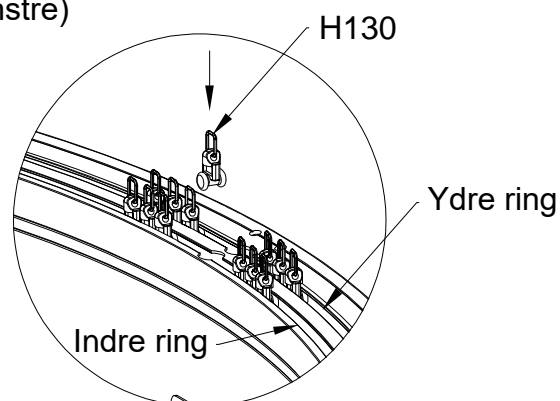
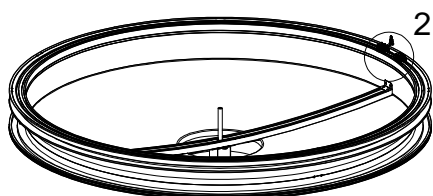

2

De 2 plastpropper monteres igen i K1 ringen

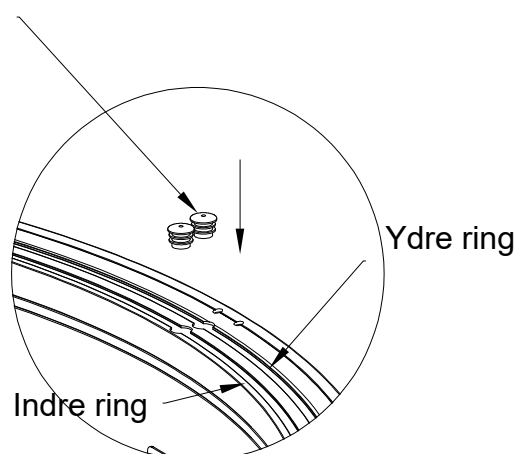
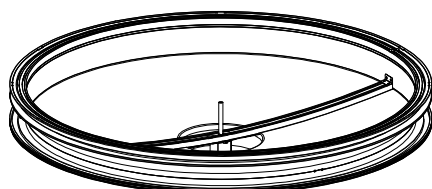

1



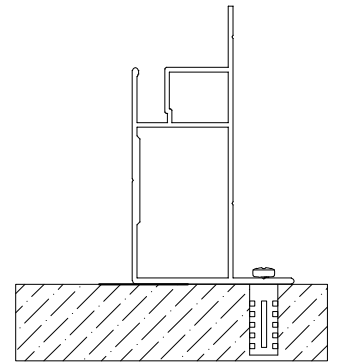
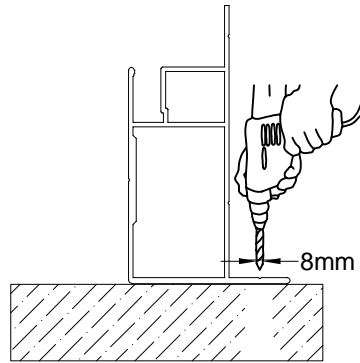
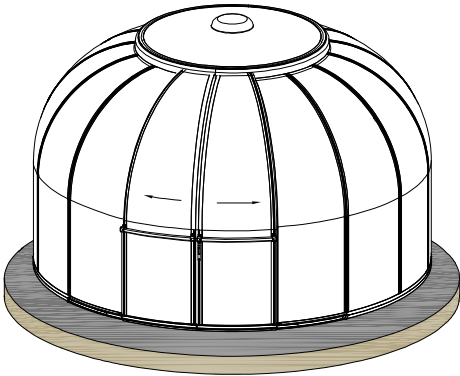

Rammen fastgøres til underlaget med træskruer, franske skrue/rawplugs eller ekspansionsbolte til beton

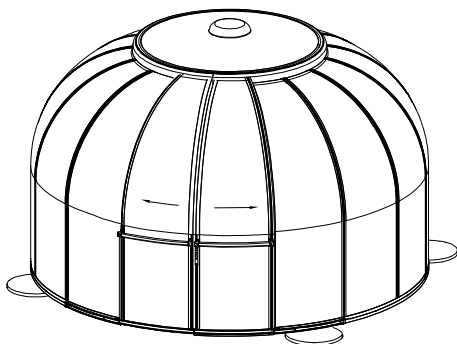
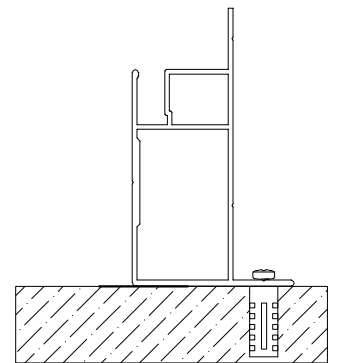
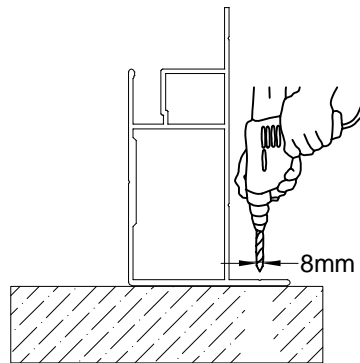
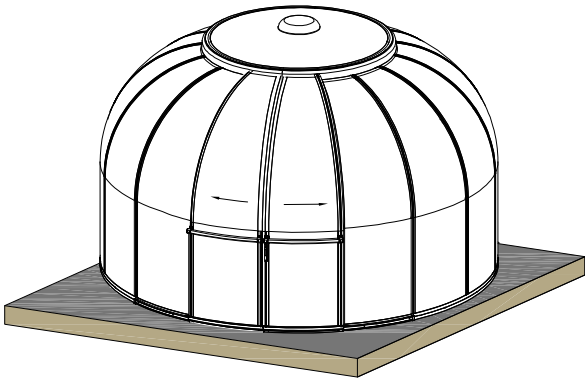

Der skal bores et antal huller indvendigt i bundrammen til montagen, typisk 12-16 stk.



Enkelte understøtningspunkter er utilstrækkeligt. Der skal være fuld understøtning på hele bundrammen.



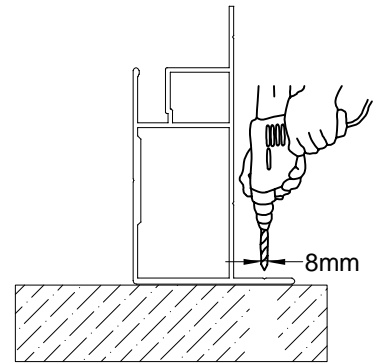
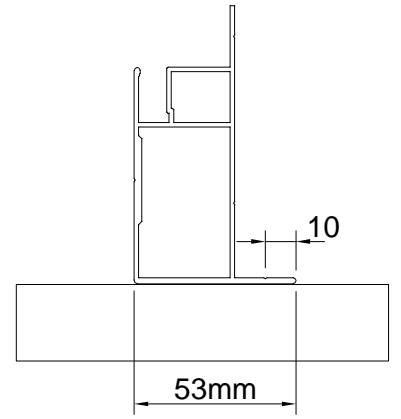
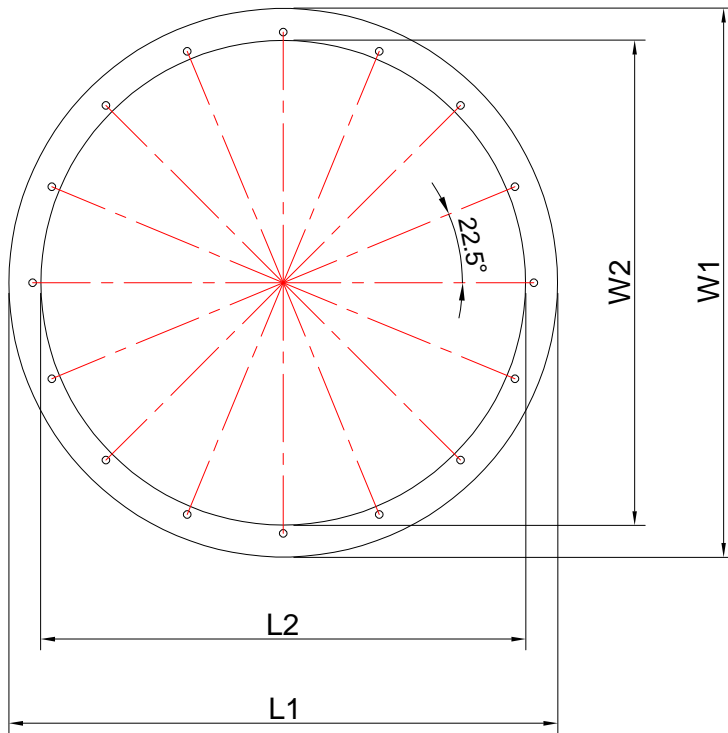

DEL	NR	STK
	J156	16
	Z13A ST5X40	16

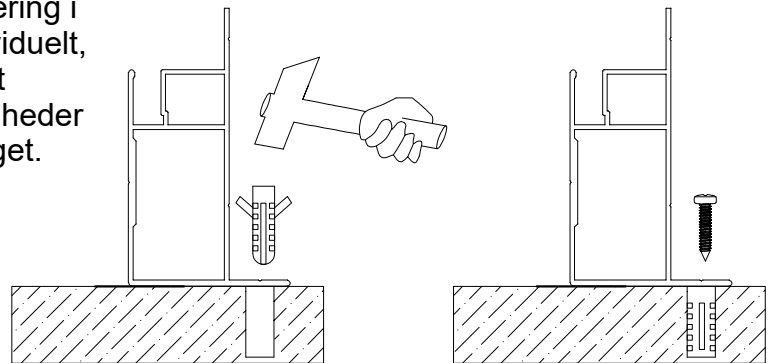

* Denne tegning viser J156 & Z13A's placering i midten af panelet. Hullerne kan laves individuelt, så det passer med underlaget. Som nævnt tidligere, er der også flere forskellige muligheder til bespænding, igen afhængigt af underlaget.





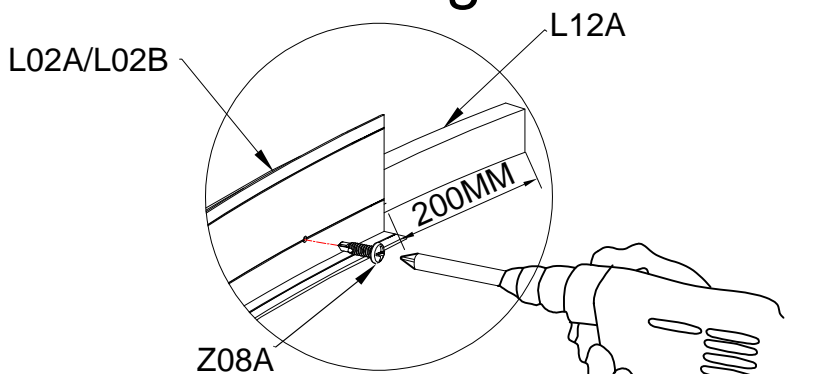

Bundramme samling

DEL	NR	STK
	L02A	3
	L02B	1
	L12A	4
	Z08A ST4.2X16	8

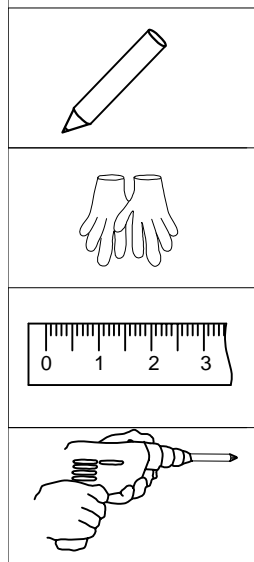
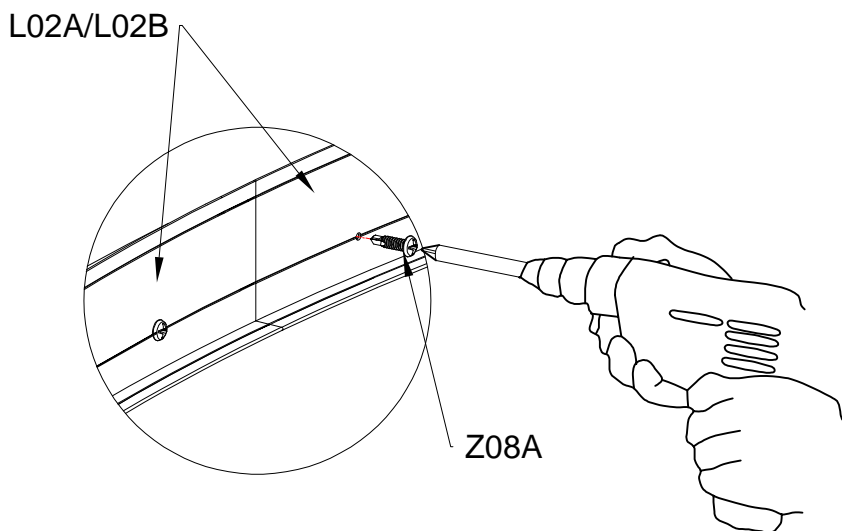
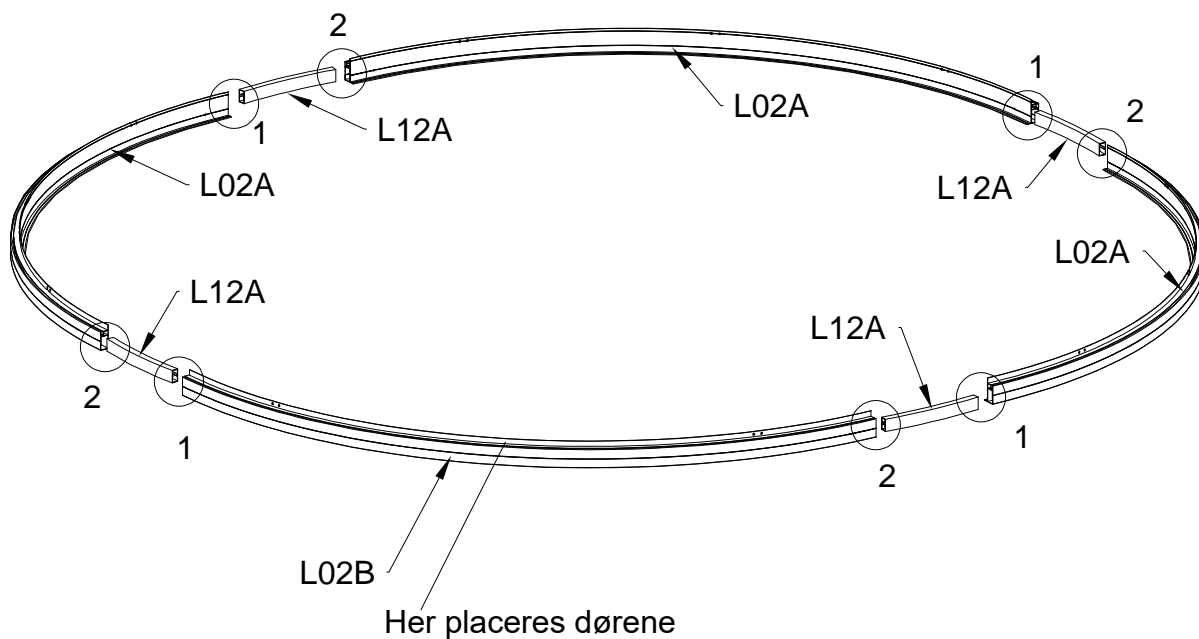



Læg alle L02A & L02B & L12A profiler ud som vist her. Skub L12A samleren, halvt ind i profil L02A & L02B. Det er ca. 200mm til hver side. Brug Z08A skruer til at fastgøre L02A samleren indefra. Sørg for at profilerne er skubbet tæt sammen, inden der bores/skrues. En skruemaskine vil være nødvendig til de selvskærende skruer og monteringen generelt.

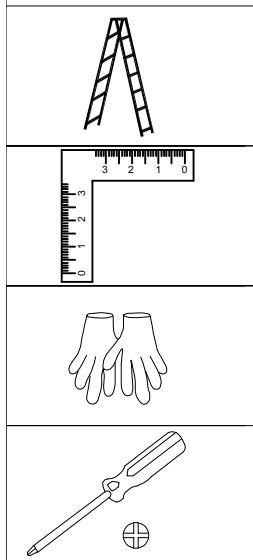
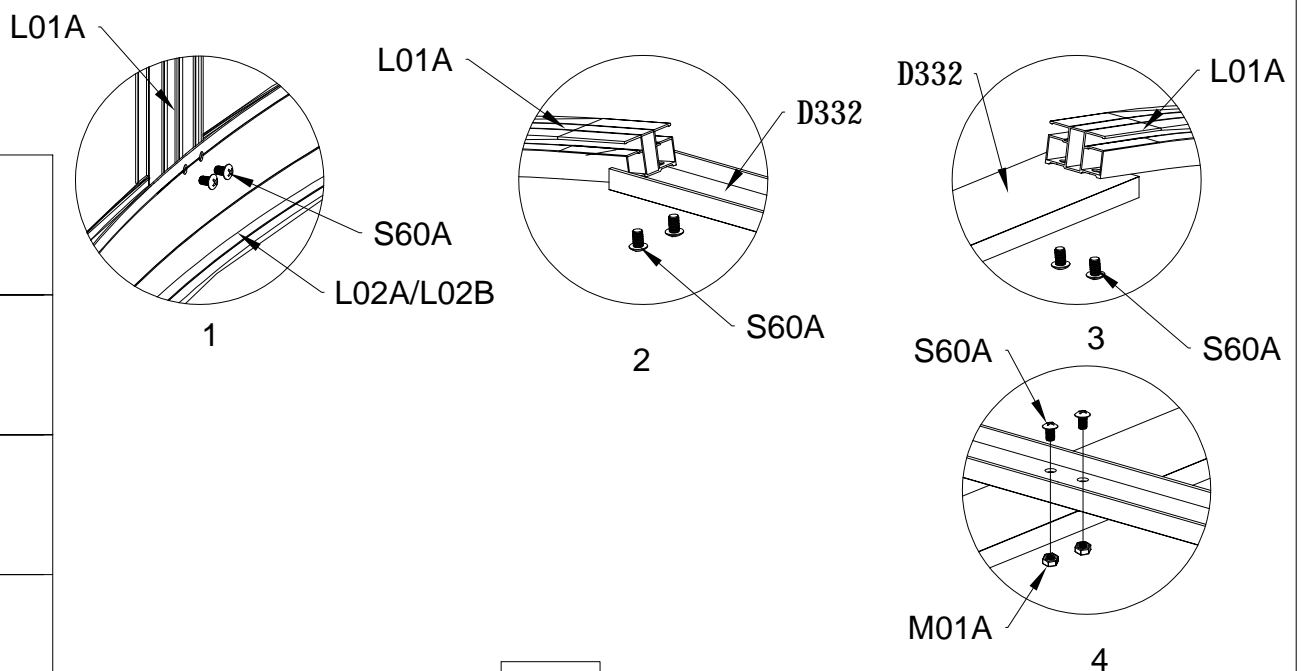
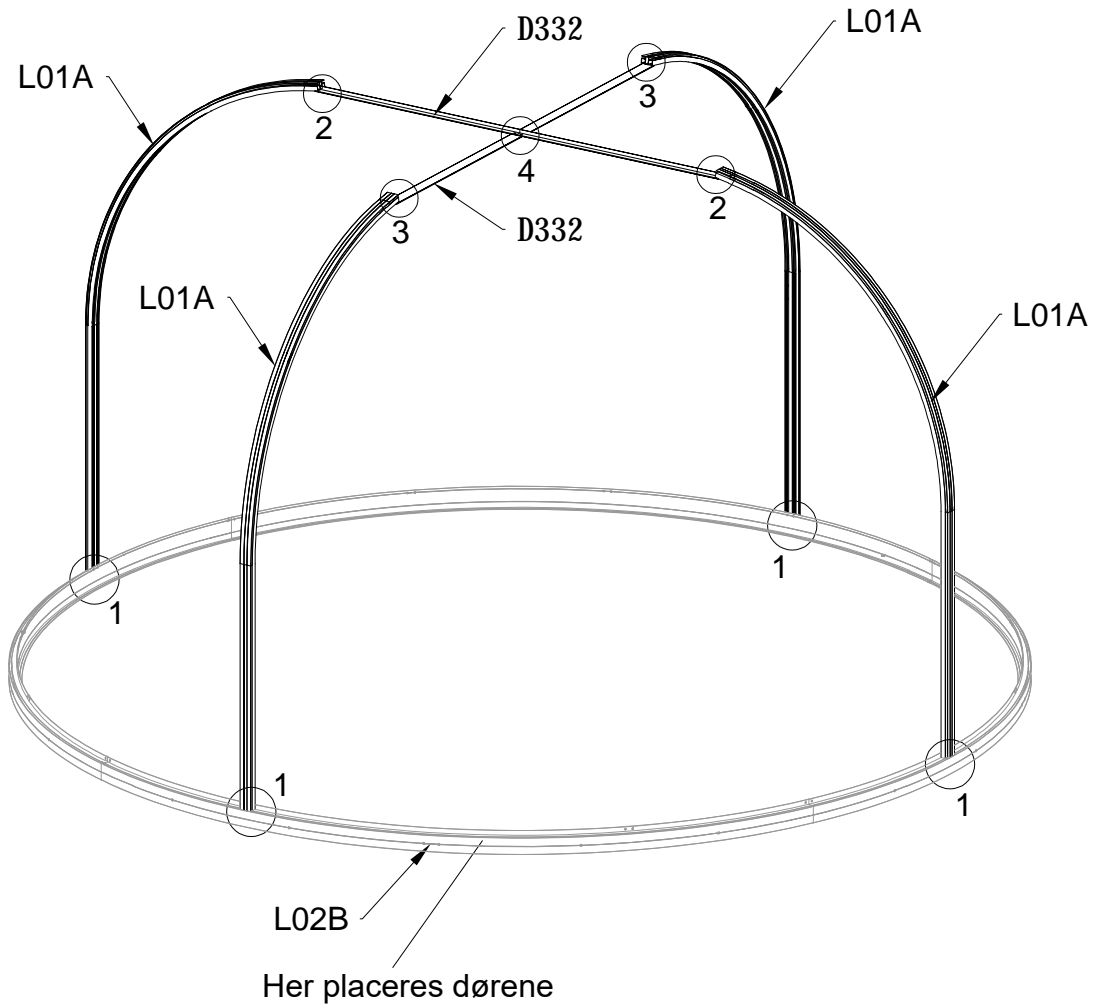

DEL	NR	STK
	L01A	4
	D332	2
	S60A M6X16	18
	M01A M6	2

Monter L01A & D332 som vist, brug skrue S60A. Vær opmærksom på at alle L01A profiler, står i en 90 graders vinkel fra bundrammen, før skruberne strammes. De 2 stk D332 er kun en midlertidig støtteanordning og fjernes igen på side 22.



DEL	NR	STK
	K1	1

K1 toppen placeres ovenpå profilerne.

Vær meget opmærksom på at stykket på K1 UDEN huller i kanten, skal placeres ud mod fronten hvor dørene placeres.

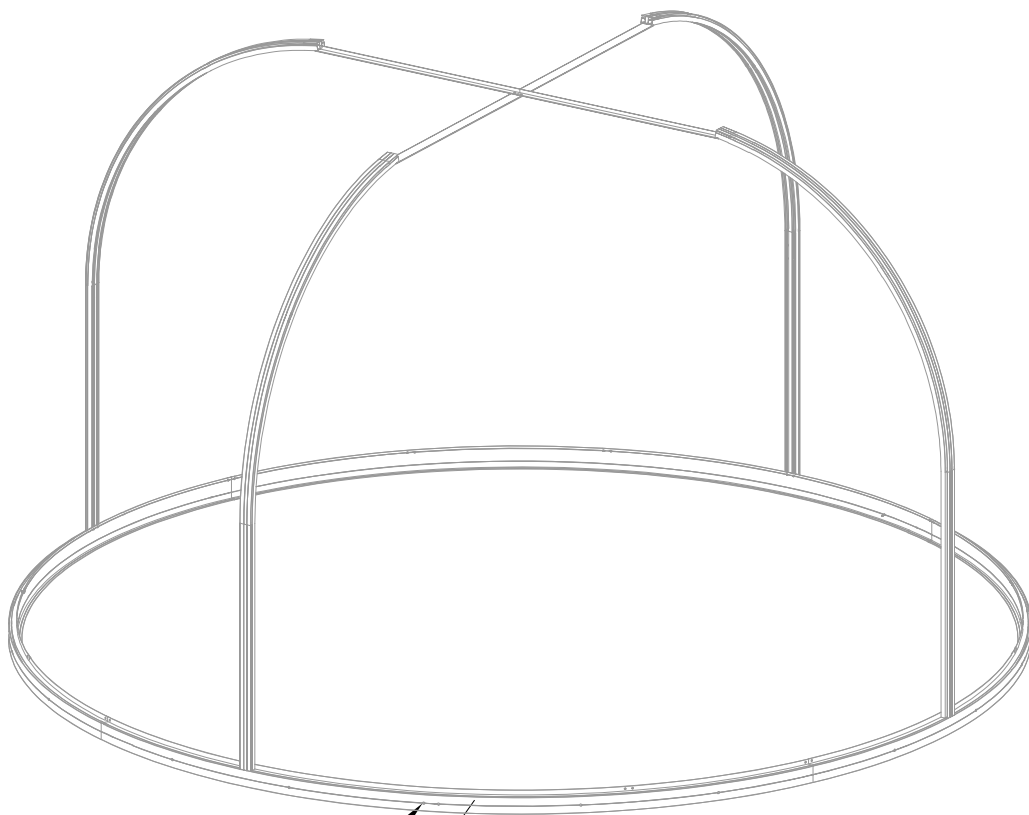
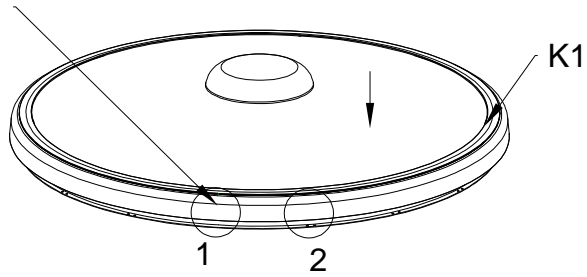

* Det er nødvendigt med mindst 2 personer til denne opgave.

L02B
Front/Døre

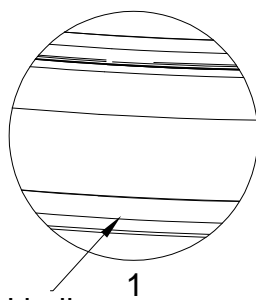

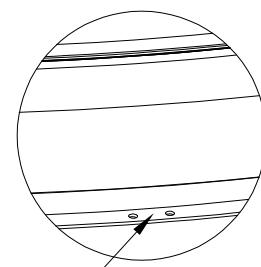

UDEN huller



Med huller

2



DEL	NR	STK
	L01A	4
	L01B	6
	S60A M6X16	40

Yderligere 10 stk L01A & L01B profiler placeres som vist her og fastgøres med S60A skruer. Vær opmærksom på at K1 toppen skal forblive centreret.

Som tidligere nævnt, skal fronten af K1 toppen uden huller, pege frem mod fronten/dørene.

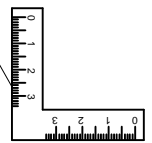
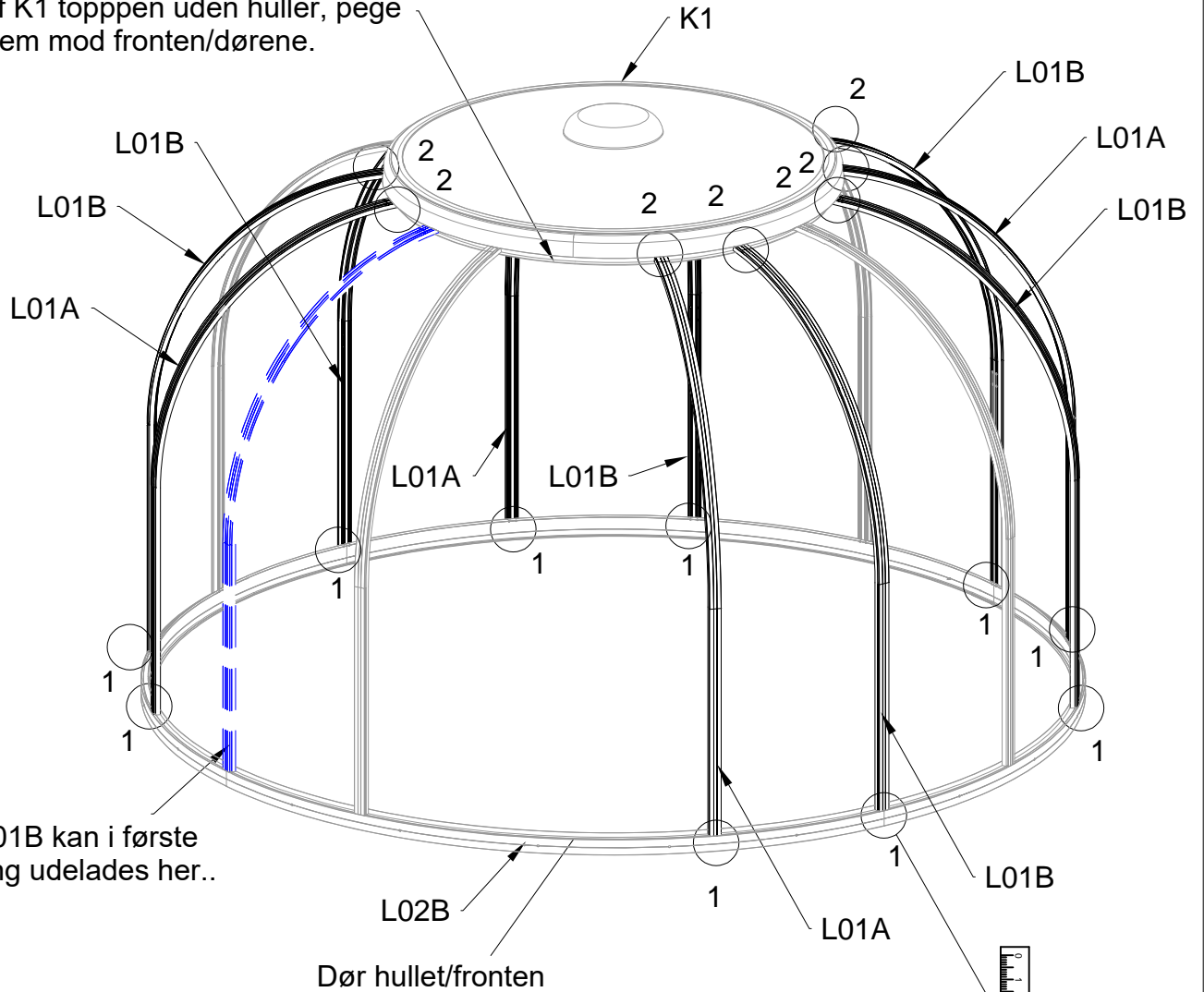

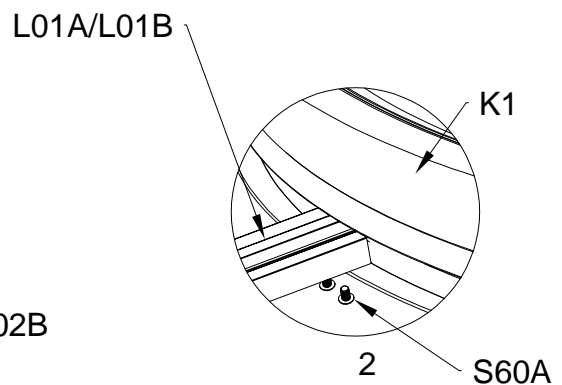
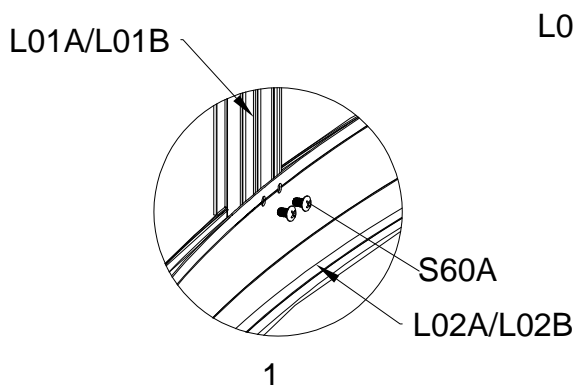
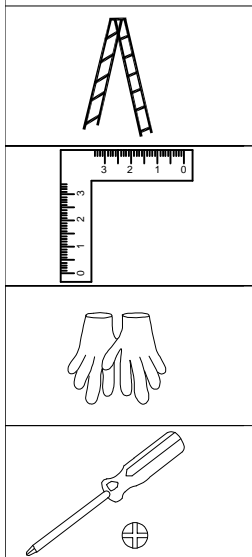

Profiler skal stå i 90 graders vinkel

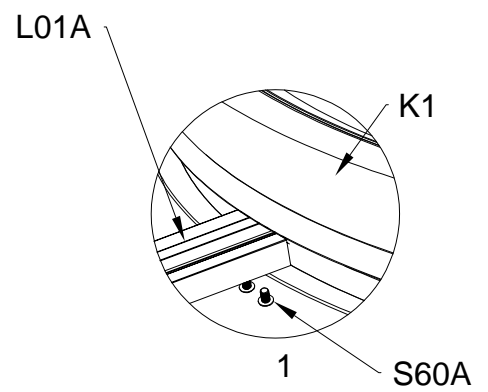
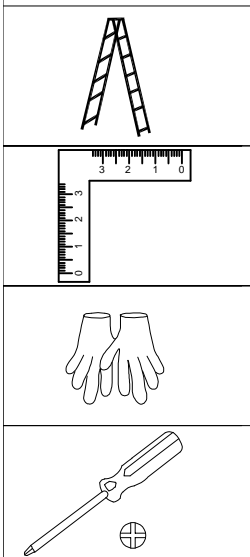
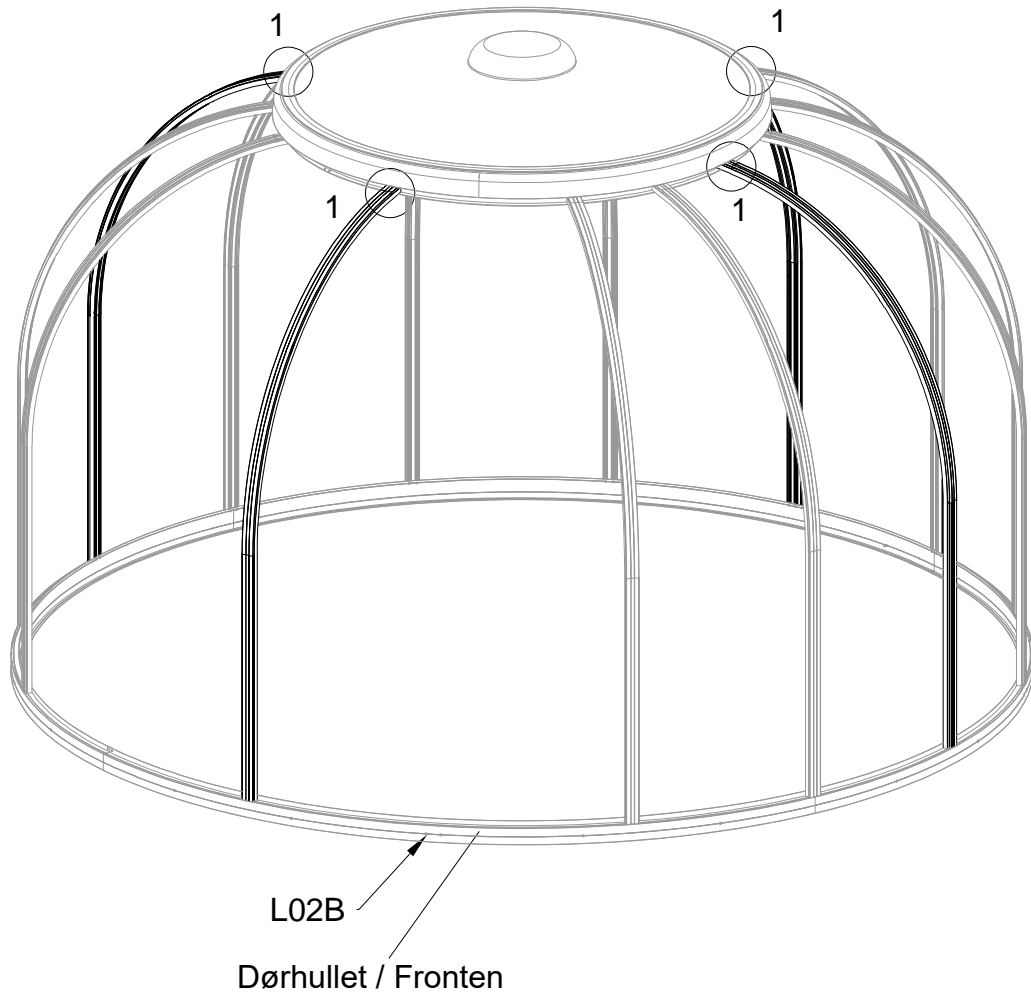

Afmonter de 2 x D332 under K1 toppen og monter istedet 4 x L01A ind til K1 med S60A skruer.



DEL	NR	STK
	Y1	1
 3,23m	J149	2
 0,87m	J149	1

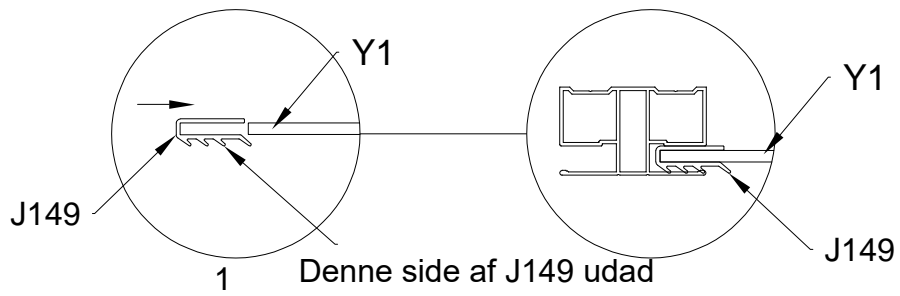

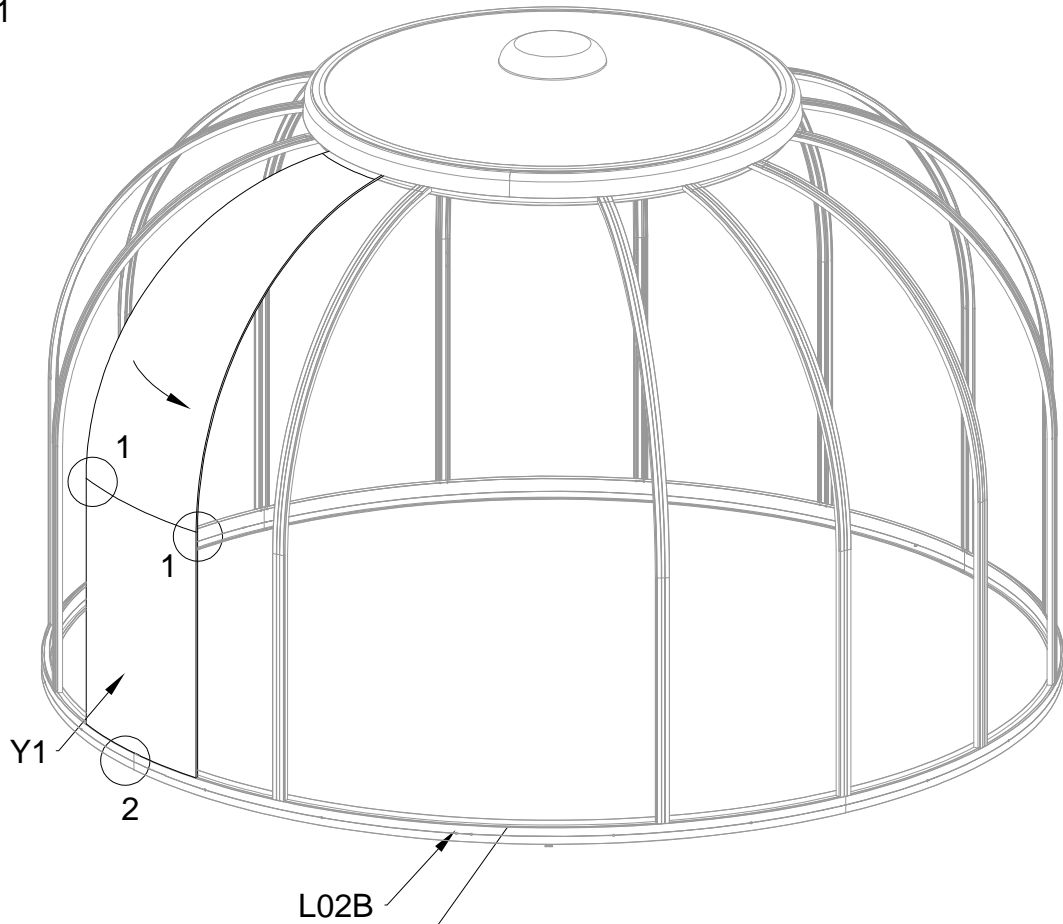
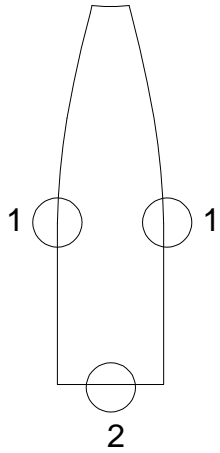

Monter gummi J149 rundt på siderne og bunden af Y1 panelet som vist her. Bemærk at der ikke skal monteres gummi i toppen.

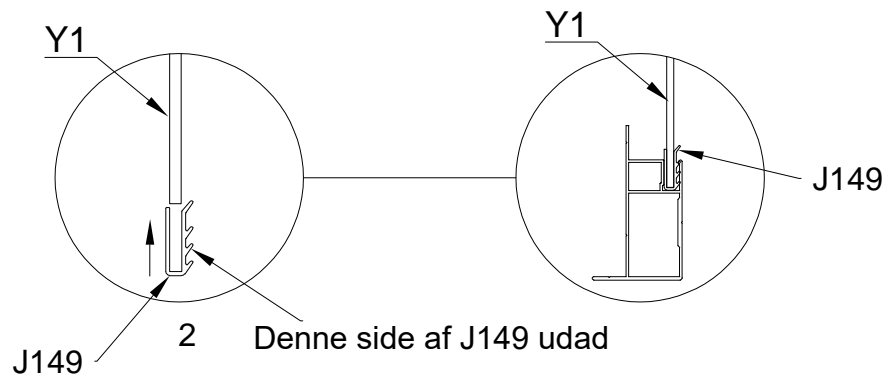
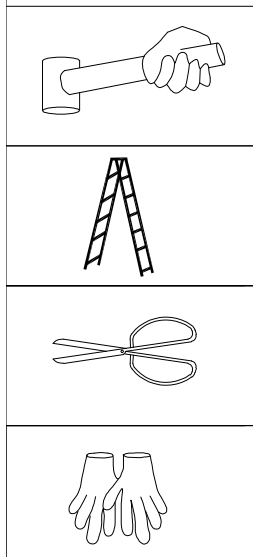

Dør hullet

Skub Y1 panelet med J149 gummi ind i top/bund og L01A profil.





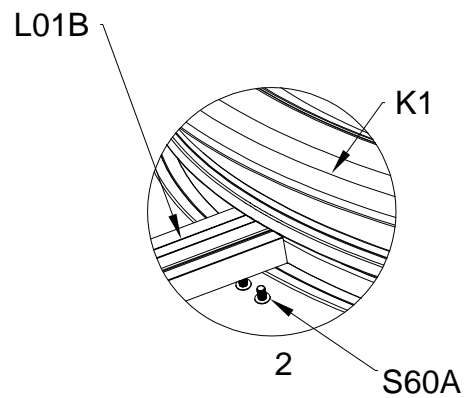
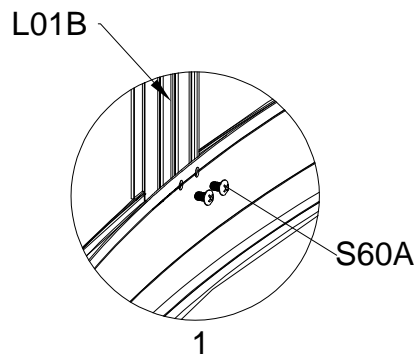

DEL	NR	STK
	L01B	1
	S60A M6X16	4

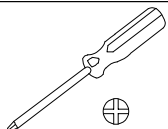
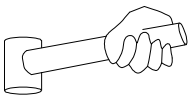
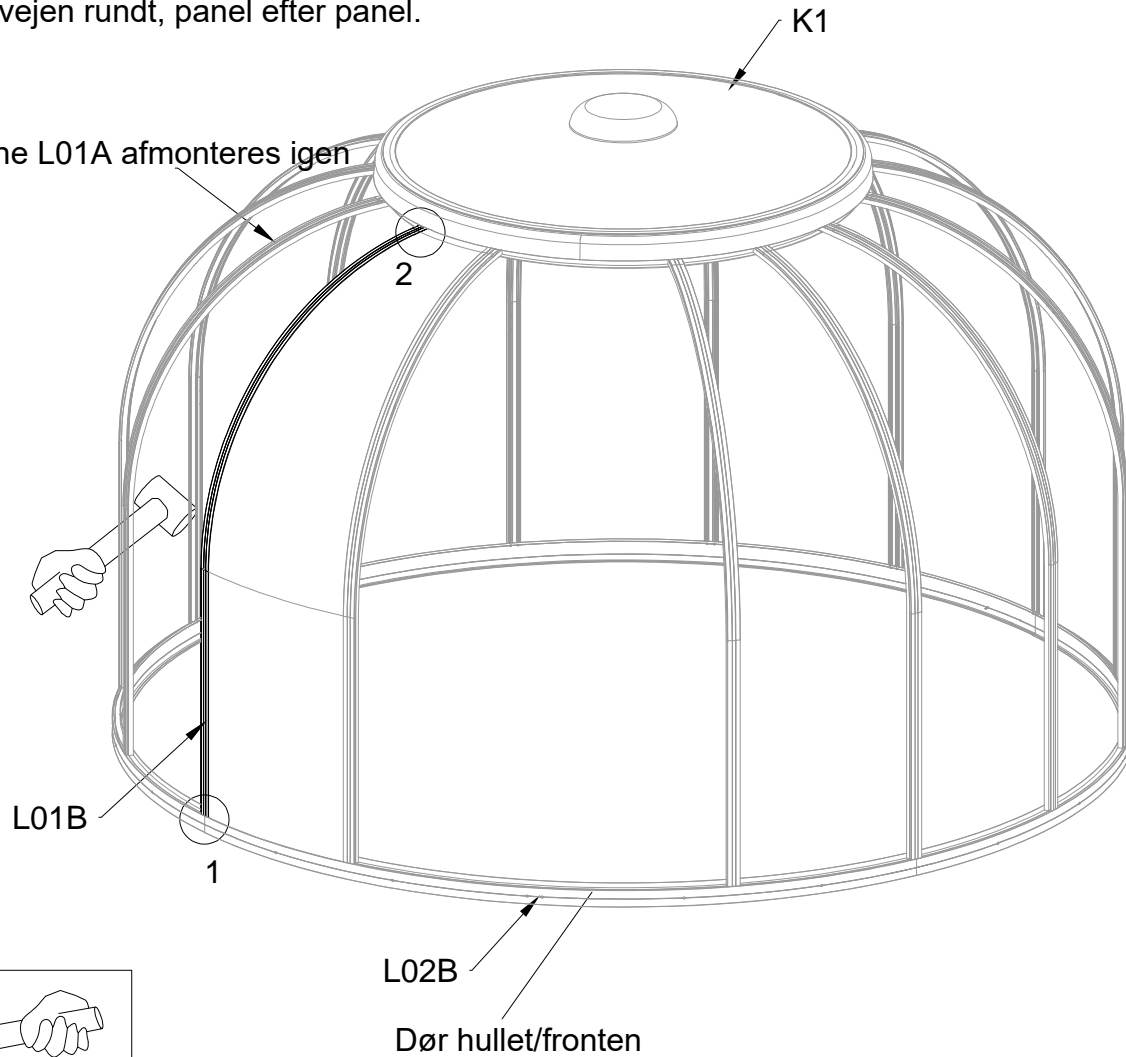

L01B profilen skubbes ind på plads, brug evt. en gummihammer. Fastgør med S60A. Derefter fjernes igen den næste L01A midlertidigt for at montere næste panel. Sådan fortsættes hele vejen rundt, panel efter panel.

*Denne L01A afmonteres igen





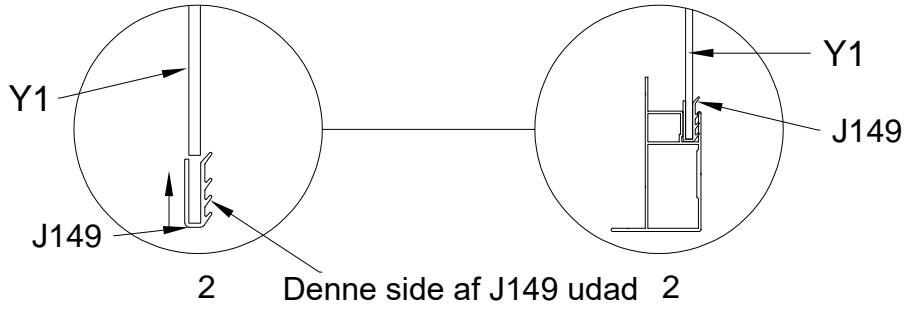
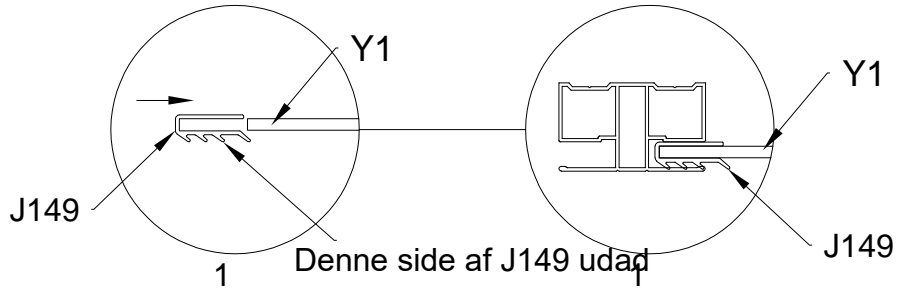

DEL	NR	STK
	Y1	13
 3,23m	J149	26
 11,31m	J149	1

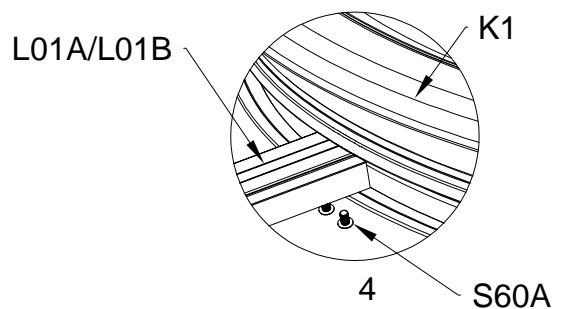
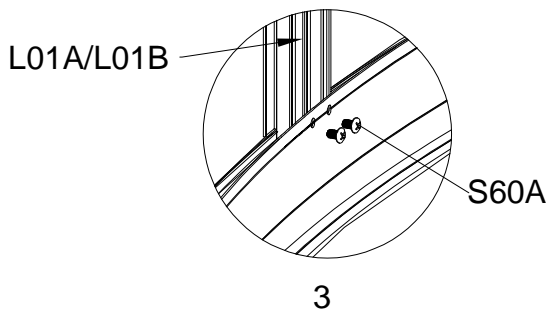
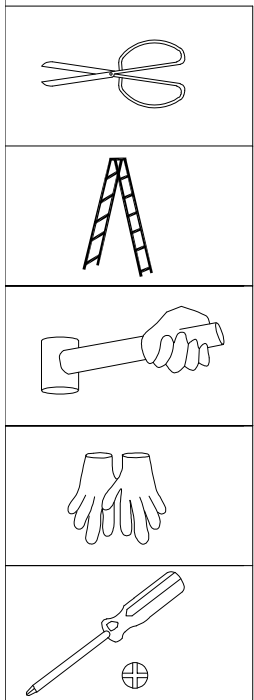
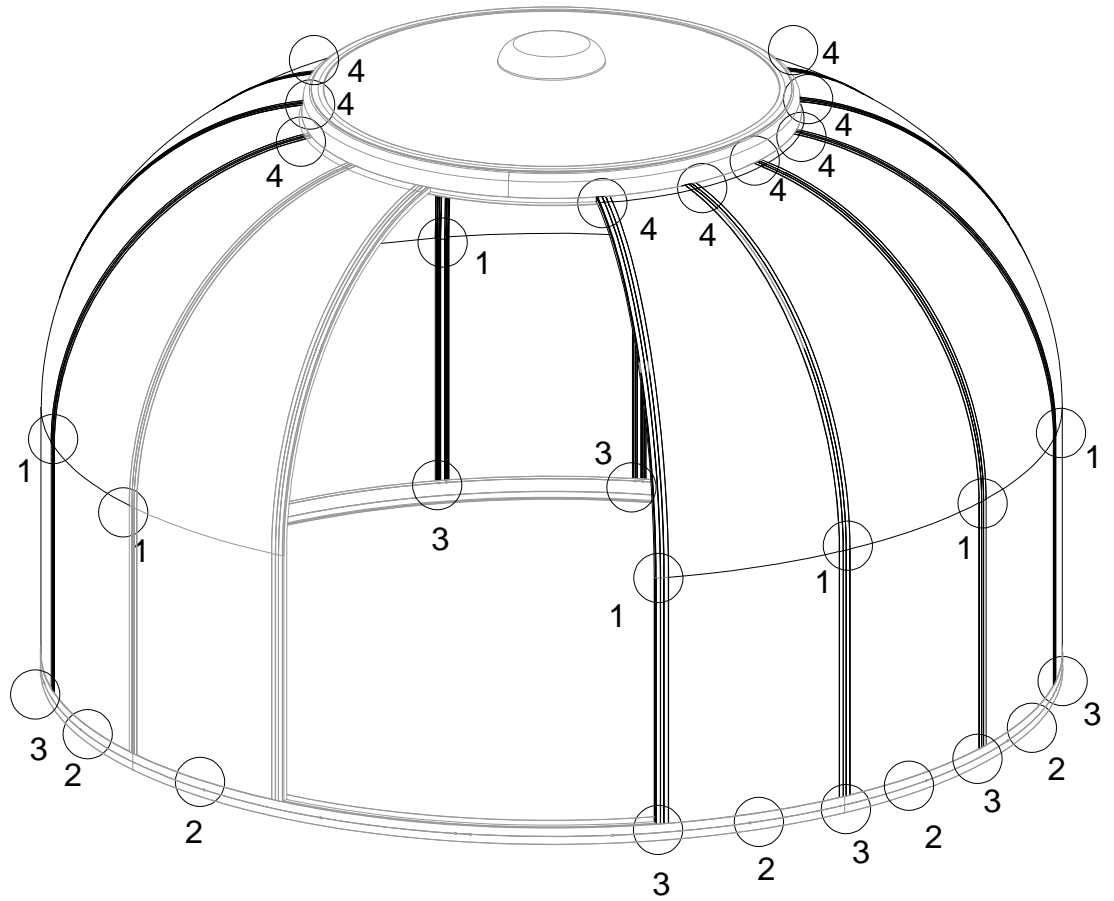
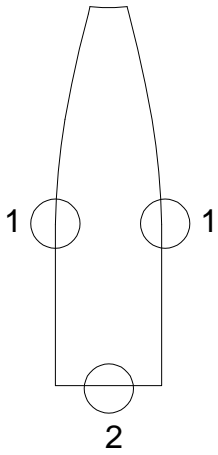

De resterende sektioner monteres en efter en, som vist på side 23-24.



DEL	NR	STK
	D318	6
	D319	2
	D321	8
	S60A M6X16	64

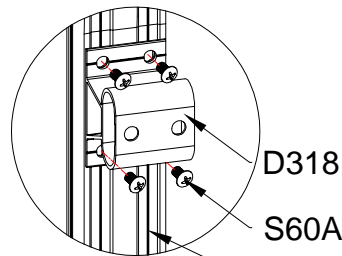

1

D318

S60A

L01A/L01B

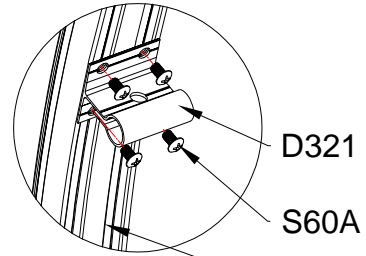

2

D321

S60A

L01A/L01B

Både D318, D319 & D321 beslag monteres som vist her, med S60A skruer

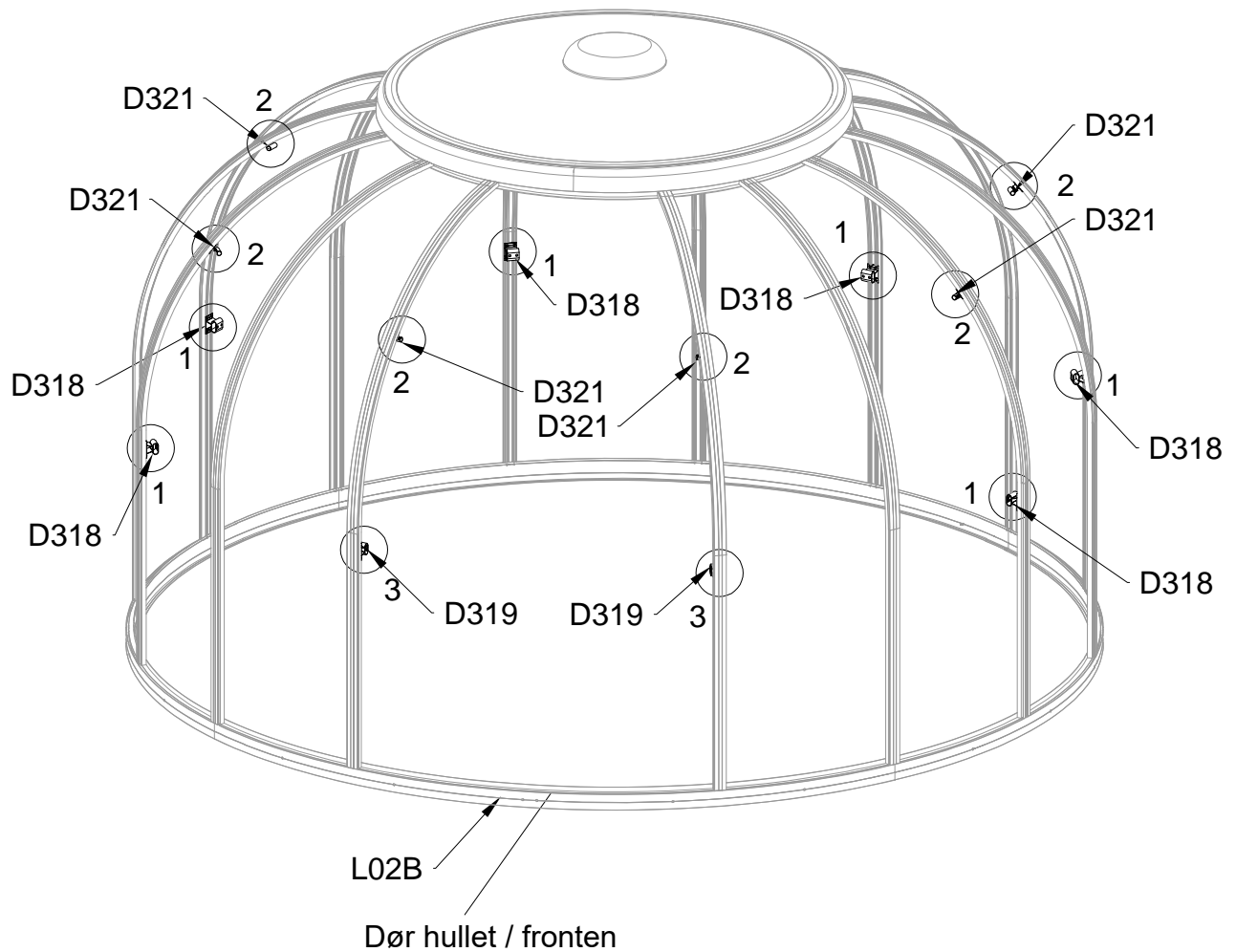

L02B

Dør hullet / fronten

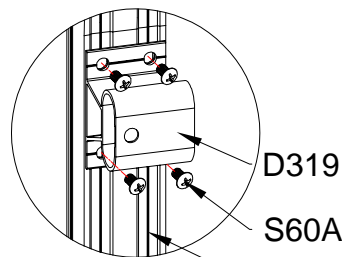





3

D319

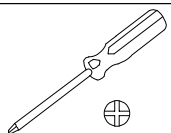
S60A







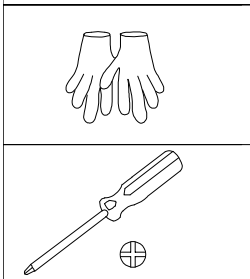
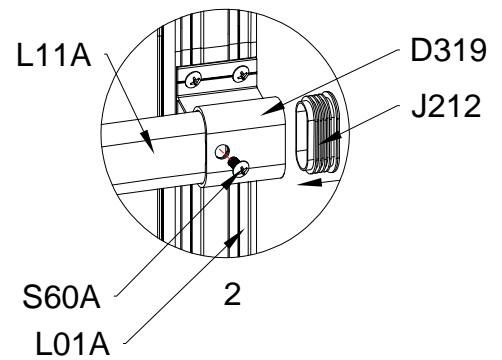
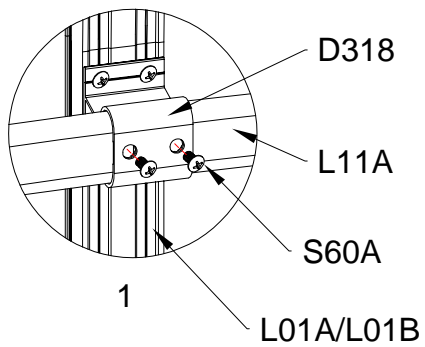
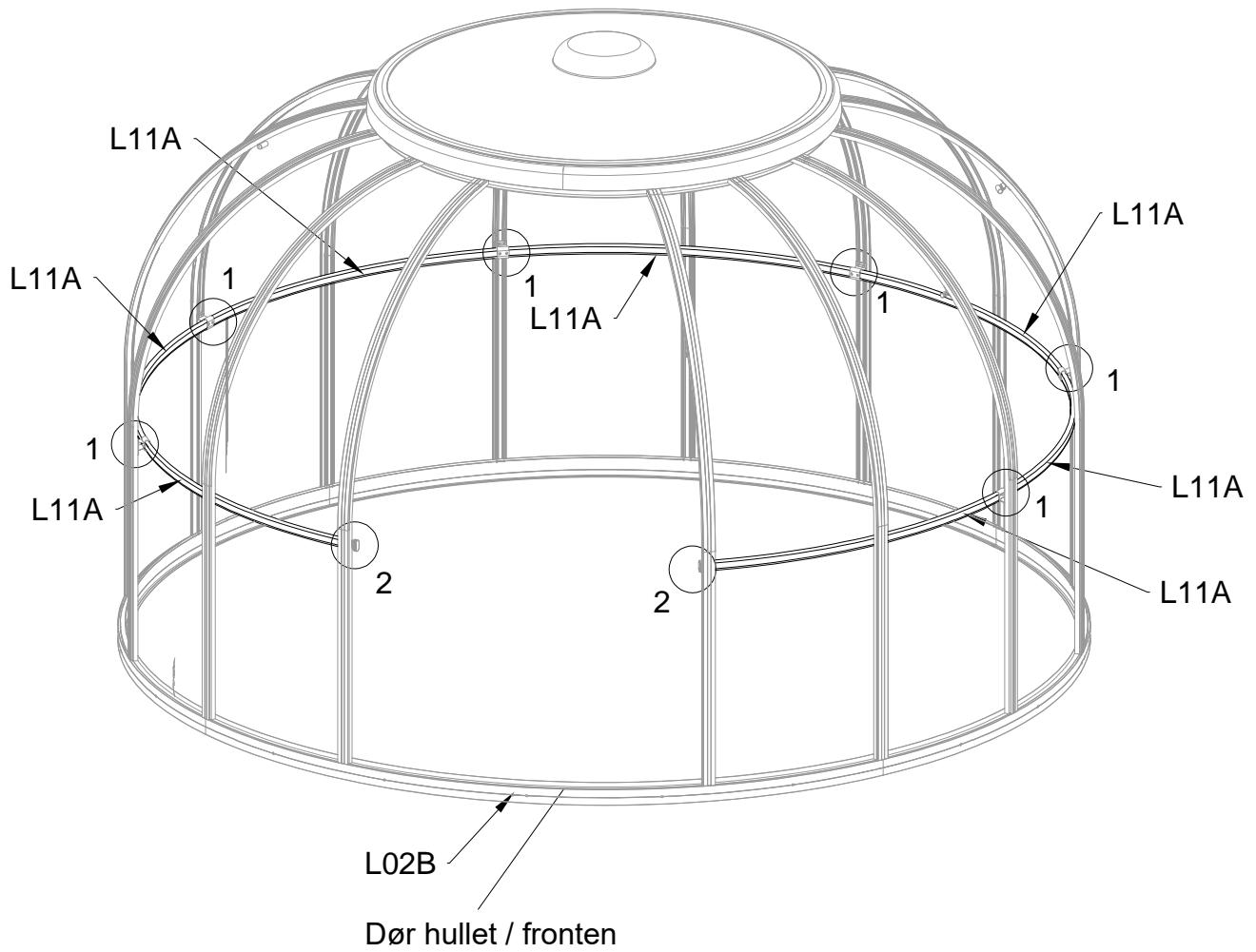

L01A



DEL	NR	STK
	L11A	7
	S60A M6X16	14
	J212	2

Monter 7 x L11A gennem D318 & D319, brug S60A.
Luk enderne af med plastic dæksel J212.







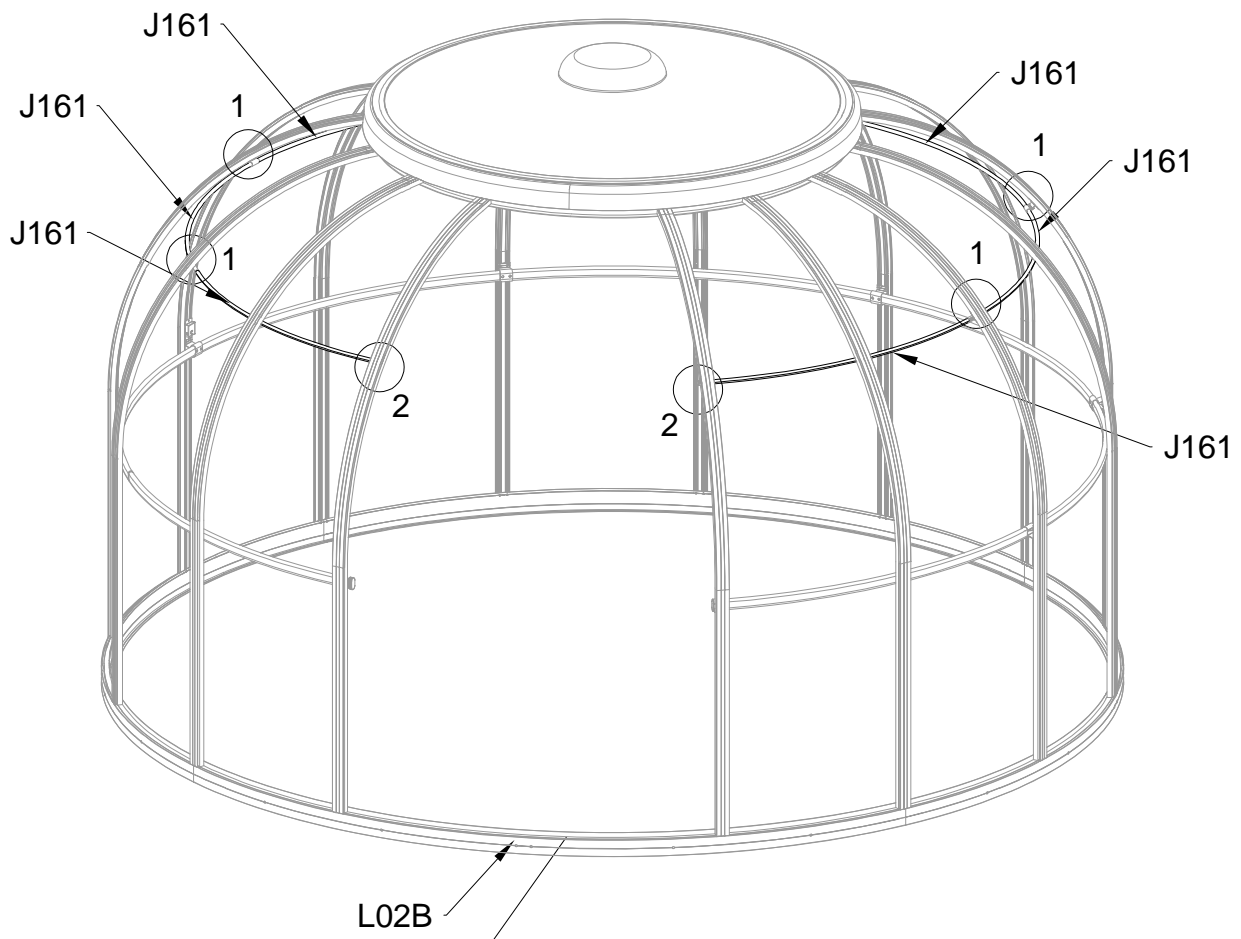
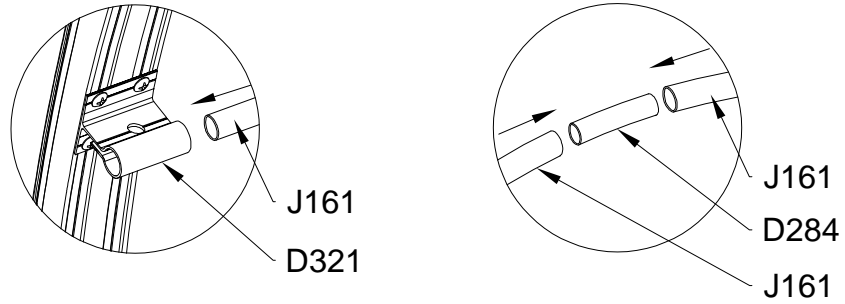

DEL	NR	STK
	J161	5
	D284	5
	M01A	8
	M6	
	M07A	8
	M6	
	S60A	8
	M6X16	
	J159	2

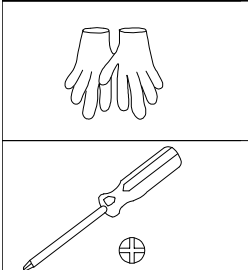
Skub plasticrør J161 ind i beslagene D321. Brug D284 samlere imellem hver J161.
 *Når alle rør er på plads, skæres/saves den overskydende del af J161 af.



Front / Dørhullet
 Brug S60A, M07A & M01A til at spænde J161 fast. Brug plastdæksel J159 i de ydre ender af D321 beslagene.



DEL	NR	STK
	L05A	1
	D278	2
	D279	2
	Z08A	4
	ST4.2X16	
	S60A	8
	M6X16	

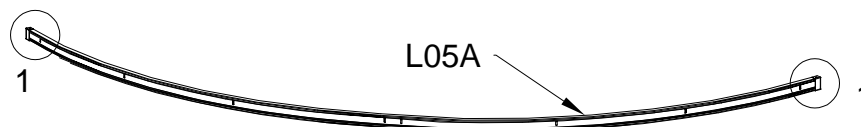
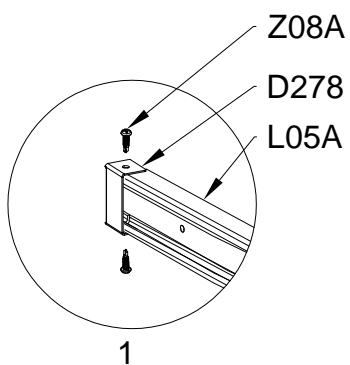

Monter D278 dæksler i begge yderender af L05A profilen.

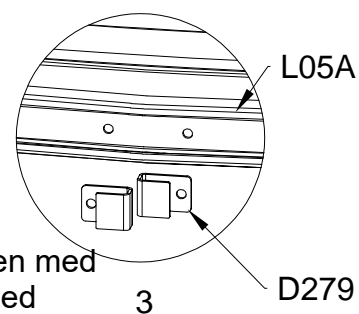
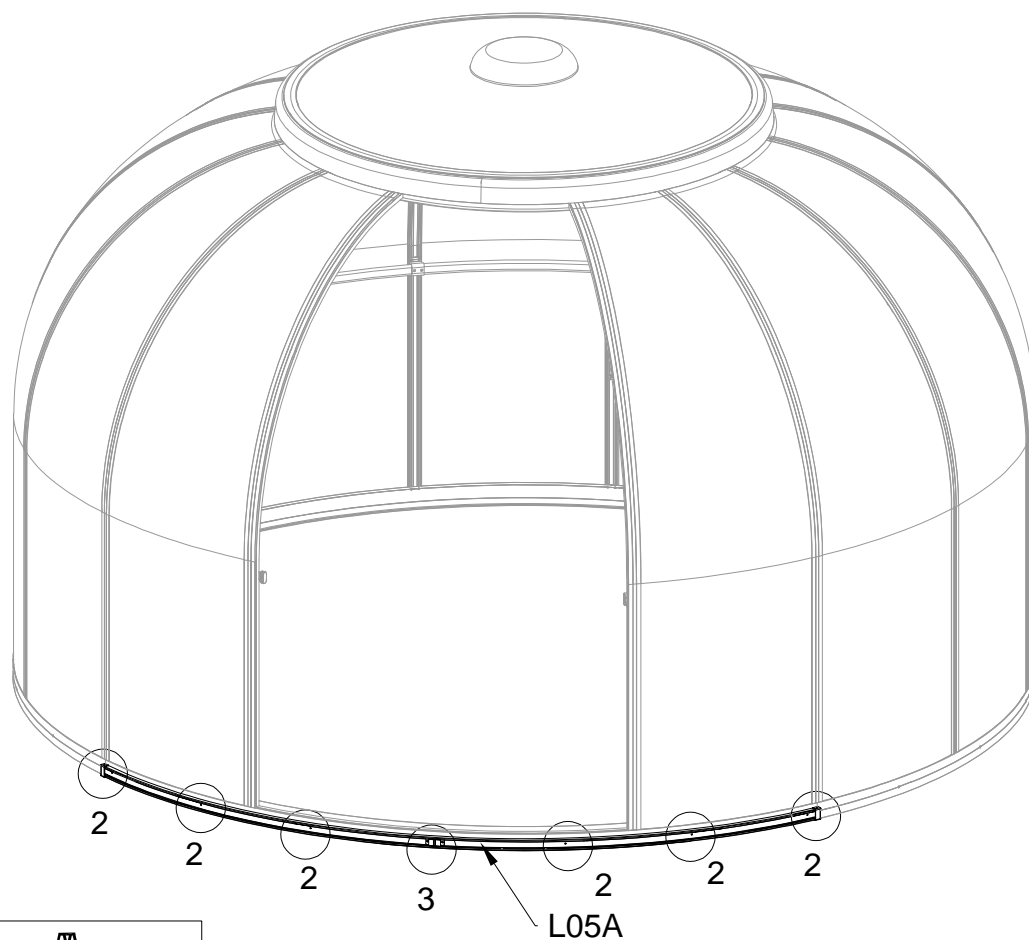

Monter de 2 dørstop D279 ryg mod ryg midt på L05A profilen med S60A. Samtidig monteres L05A profilen på bundrammen med S60A hver der er gevindbøsning og med Z08A hvor der ikke er gevindbøsning bagved.

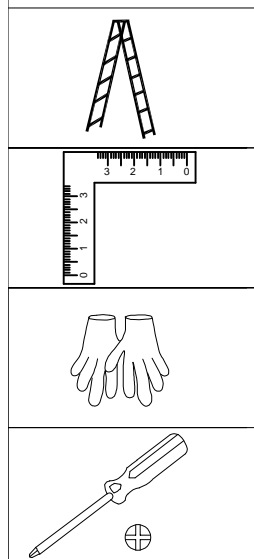
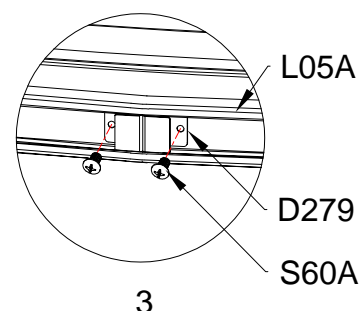
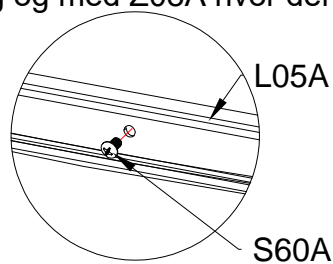

Skydedøre monteres

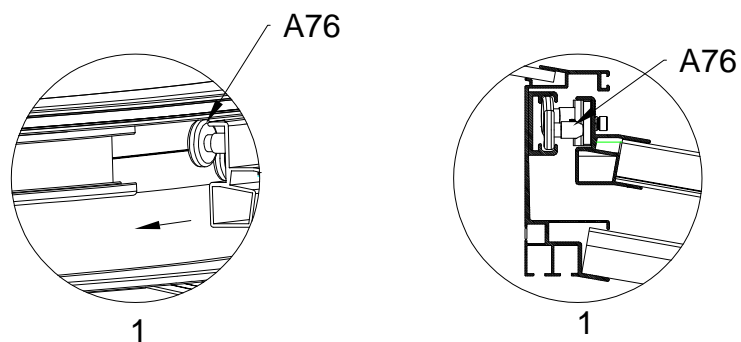

De øverste (fastspændte) hjulsæt A76 på dørene, skubbes ind i skinnen i toppen.

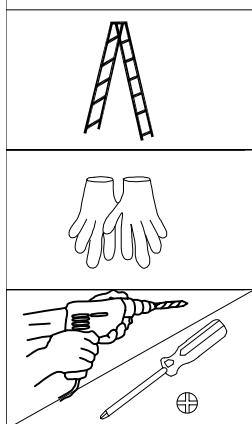
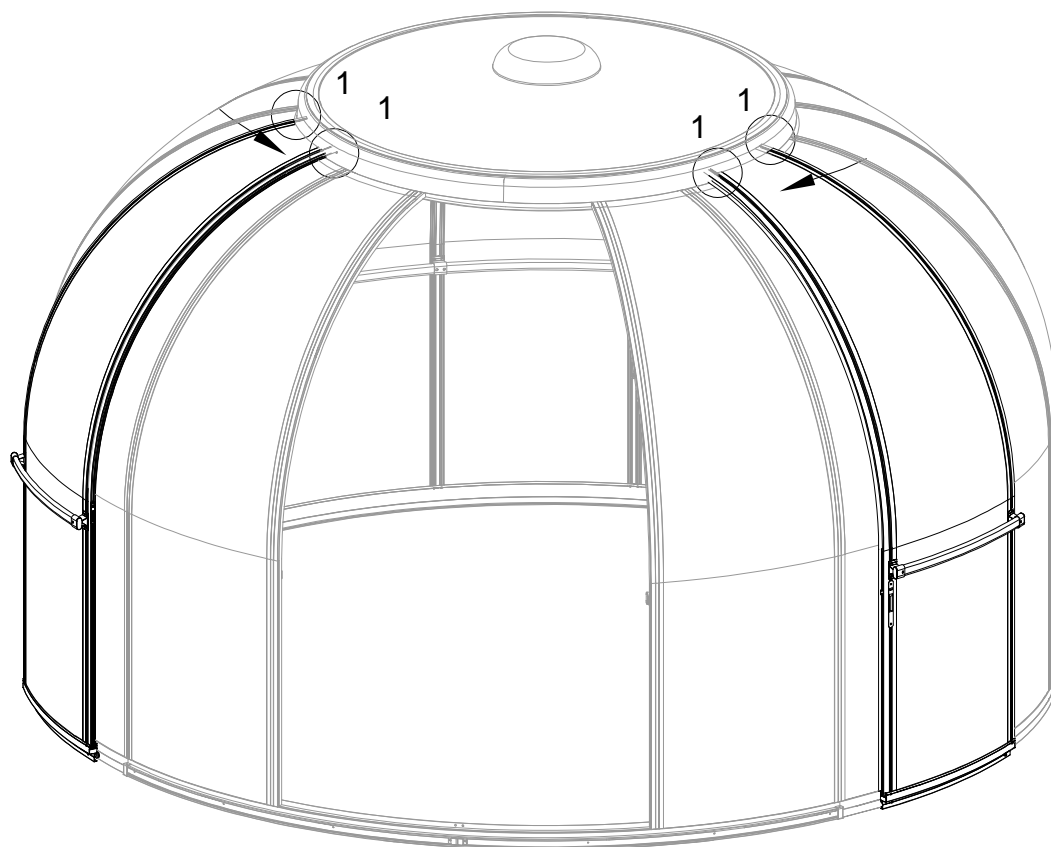

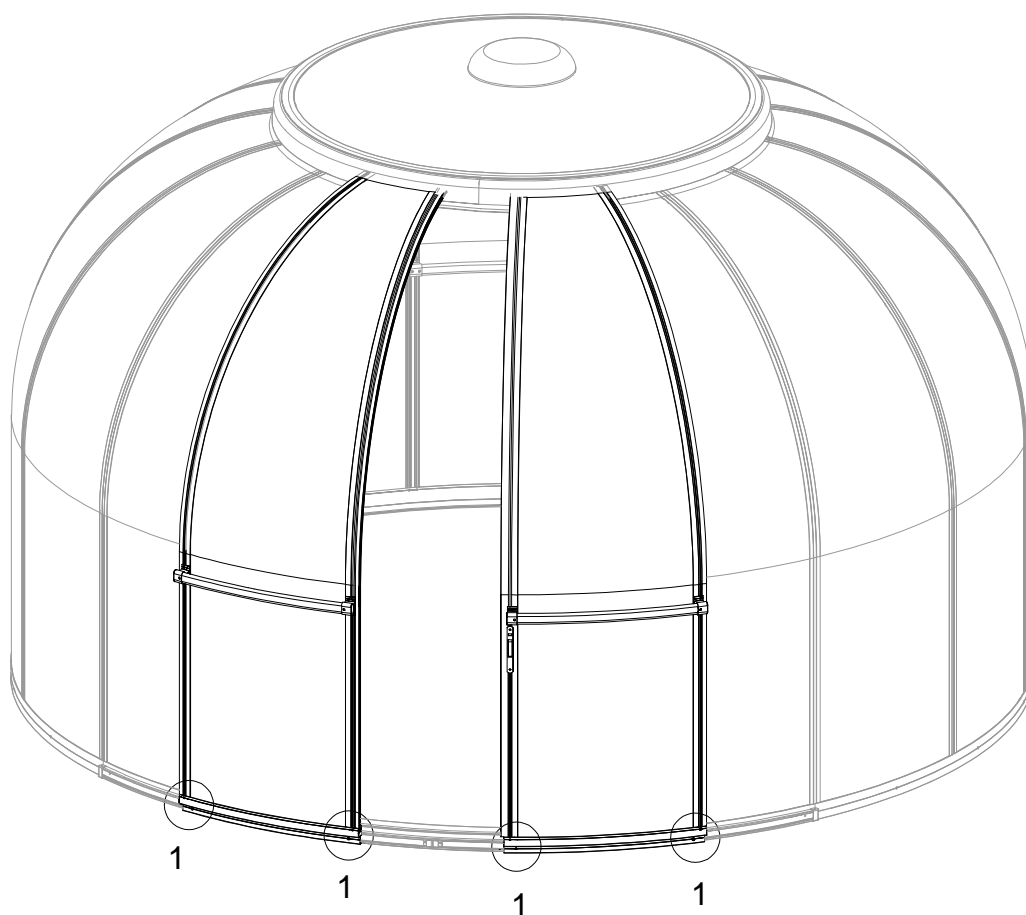

Skydedøre monteres

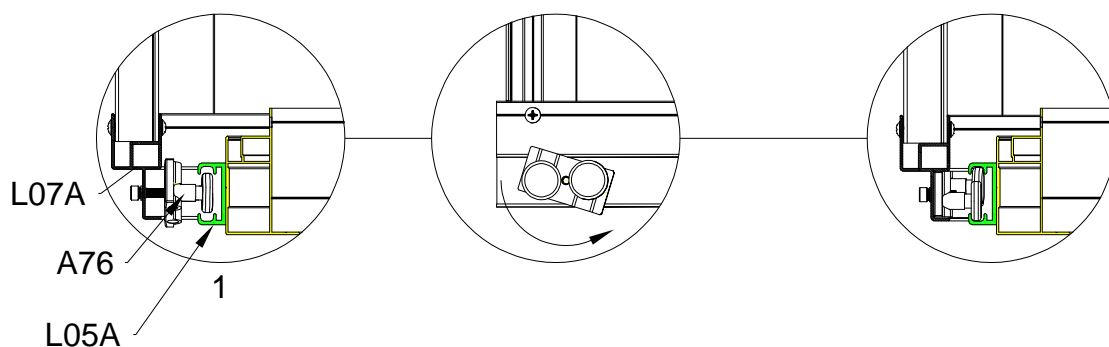
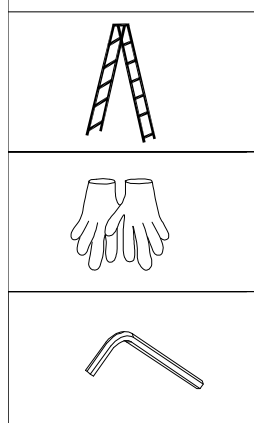

Skub de nederste hjulsæt A76 ind i skinnen L05A. Hjulsættene skal drejes lidt for at komme ind på plads. Når døren kan rulle helt på plads og hjulbasen passer i profilen, strammes S62A skruen helt.



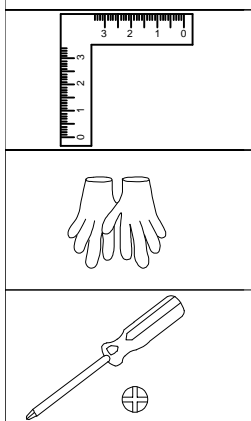
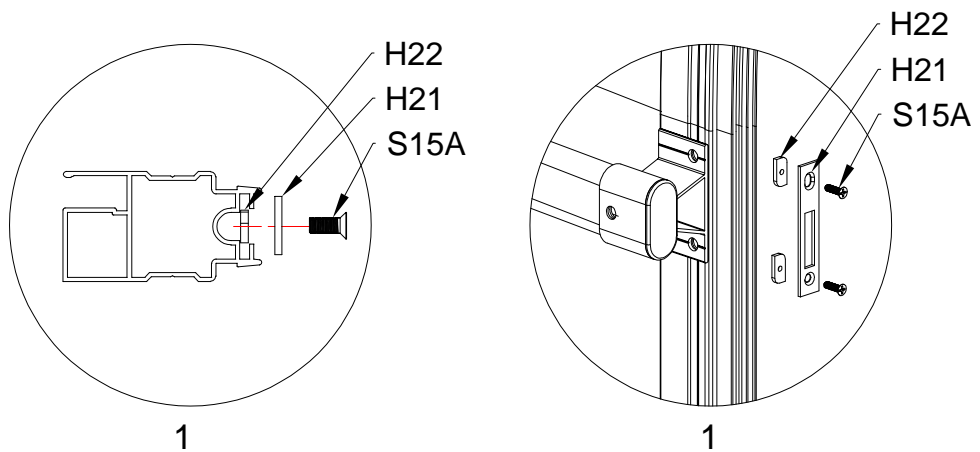
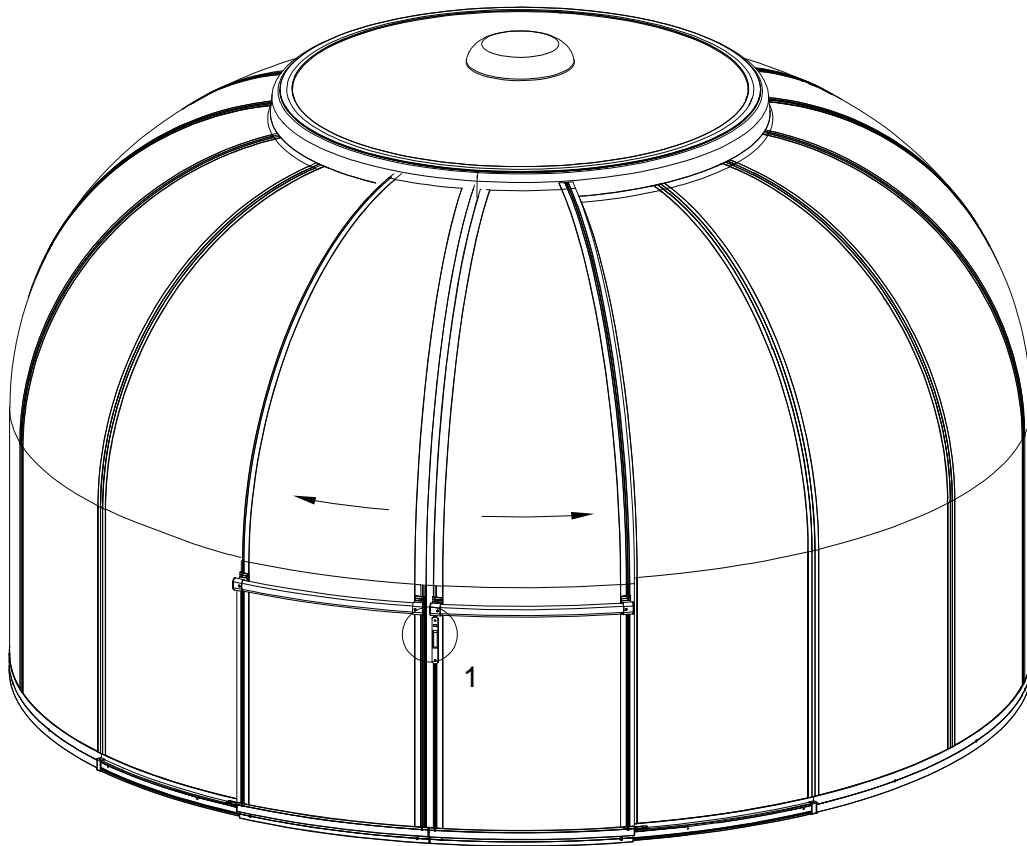

DEL	NR	STK
	S15A	2
	M4X10	
	H22	2
	M4	
	H21	1

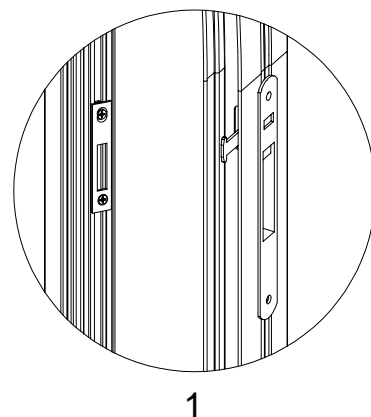

Dørlåsen skal monteres som vist her.
H21 låsepladen justeres op/ned indtil den passer ud for låsepalen.
Låsepladen H21 fastgøres med S15A skruen og H22 gevind bagved.



DEL	NR	STK
	A86	7
	J163	56

Montage af væg gardiner

(Hvis tilkøbt, ellers springes dette over)

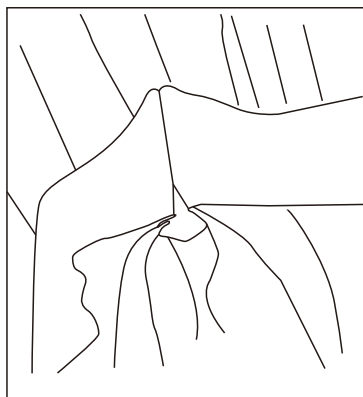

1. ind sprækken

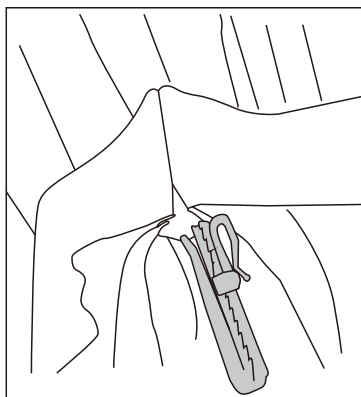

2. Monter J163

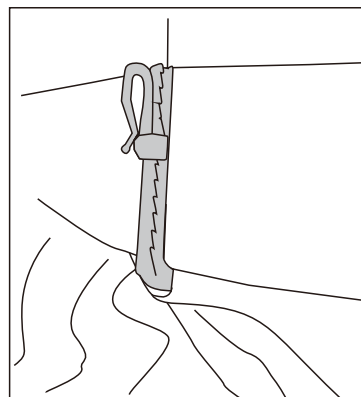

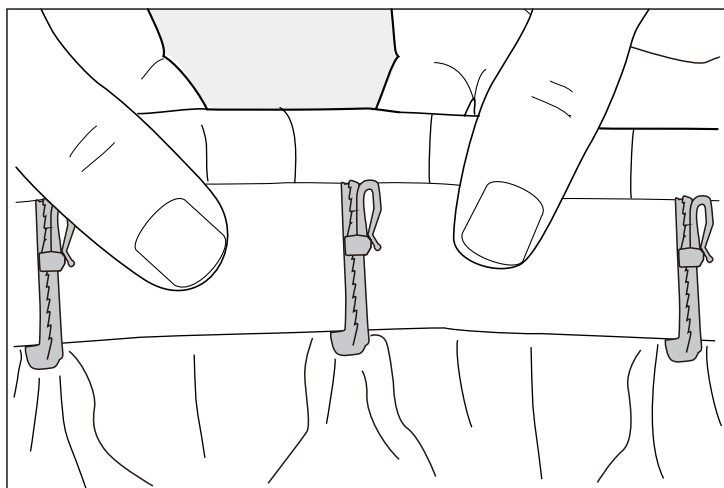

3. Skub J163 helt op

Monter 56 stk J163 i alle sprækker, 8 x J163 i hver af de 7 sektioner af gardinet A85.



Hæng alle J163 kroge på alle H130 øjer i den yderste krans på K1 Toppen

DEL	NR	STK
	A87	1
	J164	74

Montage af top gardiner (Hvis tilkøbt, ellers springes dette over)

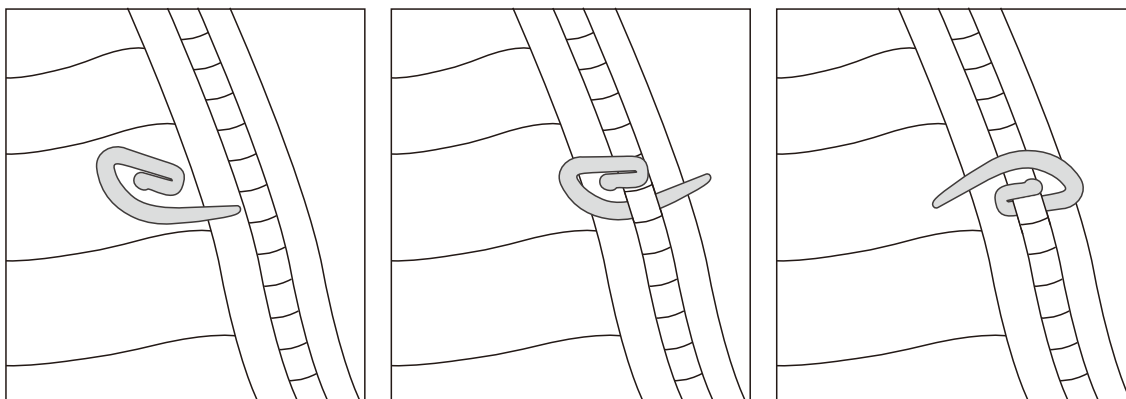

1. Find afstanden

2. Monter J164

3. Drej J164 rundt

Monter alle 74 stk J164 i hullerne som vist her, med ca. 13 cm afstand mellem hver J164

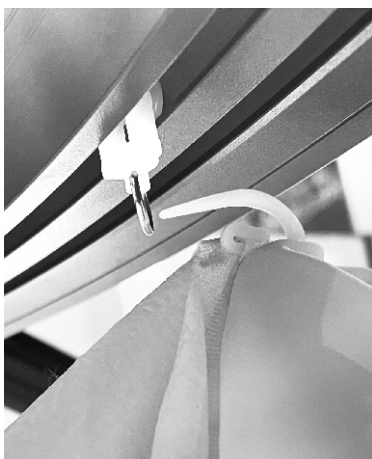
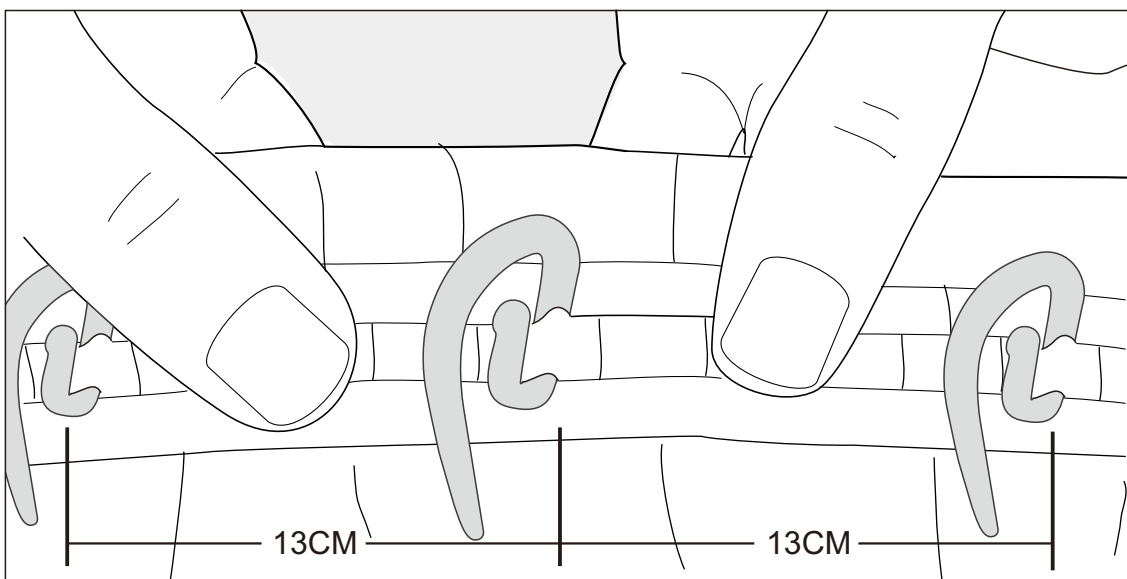

Monter alle J164 kroge på de 74 stk modsvarende H130 øjer i den indvendige krans på K1 toppen.